

P-5210 Pneumatic Pressure Transmitter

The P-5210 Pressure Transmitter is designed to measure a pressure, convert the measurement into a proportional 3 to 15 PSIG (21 to 105 kPa) output signal, and transmit the signal through air pressure piping to a pneumatic receiver controller or indicator. Pneumatic feedback and a ball type control port are incorporated to provide an exact proportional relationship between the measured pressure and the transmitted signal.

The P-5210 is a low volume output device used with an external .007 in. restrictor. The supply/output signal connection is at the top of the unit, and the measured pressure connection is at the bottom. All models are furnished with a hypodermic needle test point on the air connection to facilitate checking the transmitter output pressure.



**Fig. 1: P-5210
Pneumatic Pressure Transmitter**

A sheet metal mounting bracket is integral with the transmitter body.

Table 1: Models

P-5210 -Suffix	Operating Range	Element
-1001	-30 in. Hg to +30 PSIG (-101 to +210 kPa)	Flexible Copper Diaphragm
-1004	0 to 50 PSIG (0 to 350 kPa)	
-1010	0 to 15 PSIG (0 to 105 kPa)	
-1002	0 to 100 PSIG (0 to 700 kPa)	Flexible Stainless Steel Diaphragm
-1003	0 to 200 PSIG (0 to 1400 kPa)	
-1009*	0 to 100 PSIG (0 to 700 kPa)	

* P-5210-1009 Element has Stainless Steel Housing, Capillary, and Pipe Connection.

Specifications

Product	P-5210 Pneumatic Pressure Transmitter	
Models	See Table 1	
Action	Proportional, Direct Acting	
Output Pressure Range	3 to 15 PSIG (21 to 105 kPa)	
Ambient Temp Limits	-20 to 150°F (-29 to 66°C)	
Supply Pressure	20 PSIG (140 kPa) Nominal, 25 PSIG (175 kPa) Maximum	
Air Consumption and Output Flow Capacity	45 SCIM (12 mL/s) with .007 in. Restrictor	
Connections	Air Supply	1/8 in. NPT Barbed Fitting for 5/32 or 1/4 in. O.D. Polytubing
	Pressure Sensing	1/8 in. NPT
Materials	Body	Die Cast Aluminum with Iridite Finish
	Cover	ABS Plastic
Accessories (Order Separately)	R-3710 Series .007 in. Restrictor	
	Pigtail Siphon (Purchase Locally)	
	Stopcock (Purchase Locally)	
Shipping Weight	1.5 lb (.68 kg)	

The performance specifications are nominal and conform to acceptable industry standards. For application at conditions beyond these specifications, consult the local Johnson Controls office. Johnson Controls, Inc. shall not be liable for damages resulting from misapplication or misuse of its products.

Operation

The P-5210 provides an accurate linear output pressure signal which is directly proportional to the sensed pressure. The output signal of 3 to 15 PSIG (21 to 105 kPa) is in direct response to pressure changes within the operating range. This output signal is transmitted to a receiver such as an indicator, recorder, controller, or any combination of these instruments.

Application and Drawing Identification

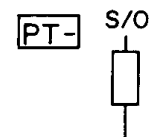

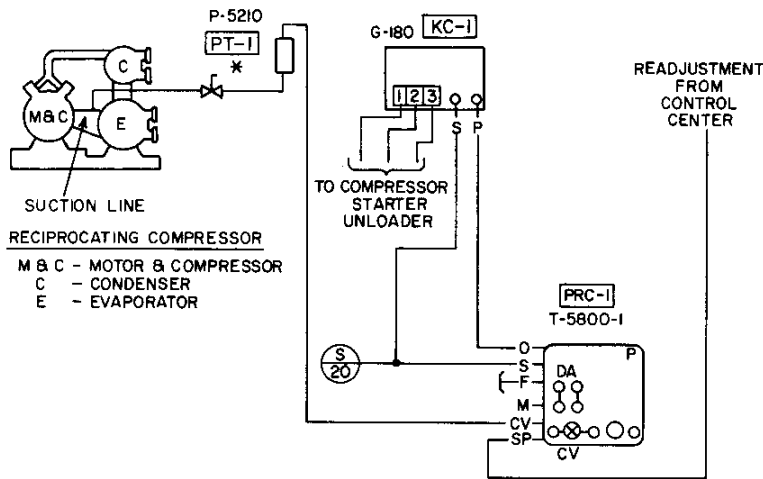

Fig. 2: Compressor Capacity Control From Suction Pressure

* Note: When sensing ammonia, use model P-5210-1009 with stainless steel element, housing, capillary, and pipe connection.

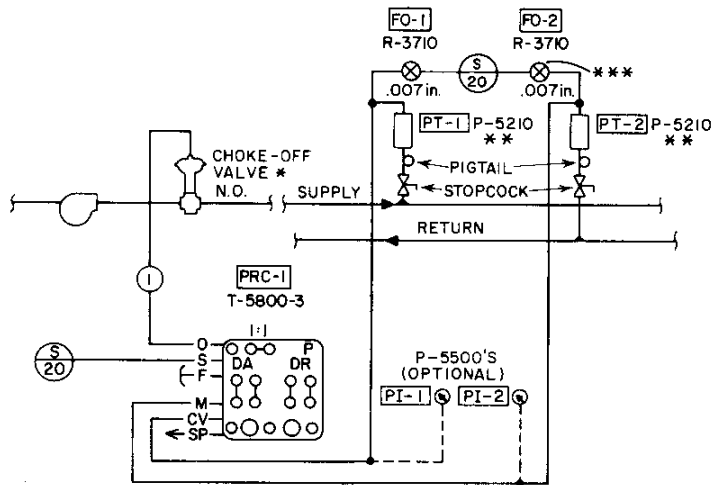

Fig. 3: Hydronic System Pressure Control

* Note: Valve selection is determined by maximum drop across valve (Johnson Controls or industrial).

** Note: Install the transmitters 2 to 3 ft. (61 to 91 cm) from the pressure tap for steam applications. The pressure transmitters should be located near the middle of the heating or cooling system (halfway between the choke-off valve and the last terminal unit).

*** Note: Restrictors must be located near the transmitters when the transmission lines from the receiver-controller are longer than 50 ft. (15 m).

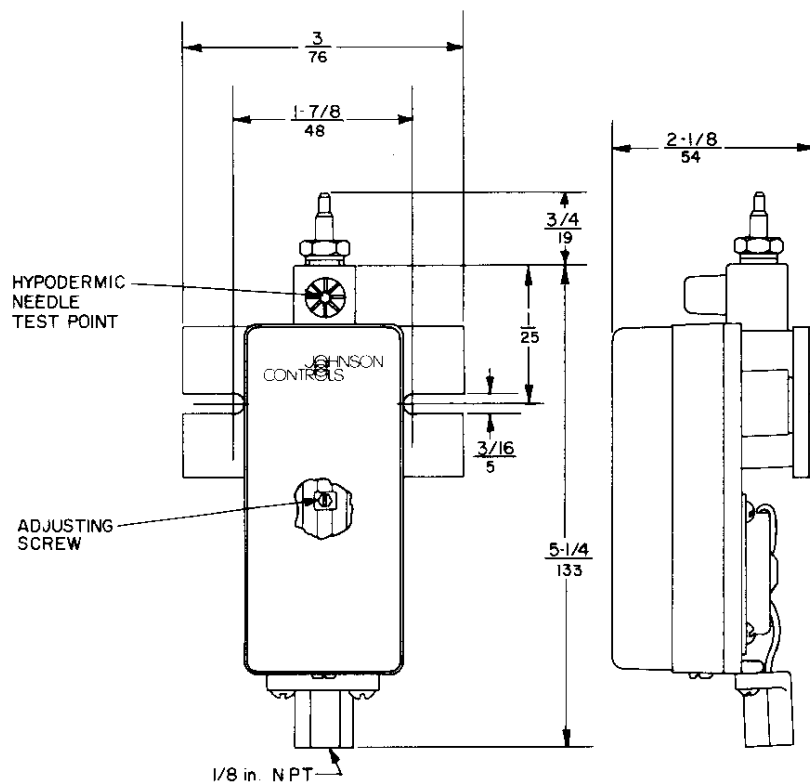

Fig. 4: P-5210 Dimensions $\frac{\text{in.}}{\text{mm}}$

Installation

The P-5210 is designed for surface mounting in any position on any comparatively vibration-free surface. Use the mounting bracket to attach the unit to walls, duct work, piping, etc. The transmitter can also be self-supported in applications where the measured pressure connection at the bottom of the unit is screwed onto a rigid pipe.

On high pressure steam applications, a pigtail siphon and stopcock must be added to the sensing line to eliminate raw

steam from coming in direct contact with the sensing element. A pigtail and stopcock should also be installed on all liquid applications to absorb shock, and on high temperature and corrosive chemical applications to isolate the sensing diaphragm. The P-5210 must be installed 2 to 3 ft (61 to 91 cm) from the pressure tap on steam applications.

Repair Information

Field repairs must not be made. For a replacement P-5210, contact the nearest Johnson Controls branch office.

Operational Checkout

The P-5210 is factory calibrated with a fixed span. The transmitter can be checked and fine tuned as follows:

1. Accurately measure the pressure at the element.
2. Referring to Fig. 5, find the proper output pressure corresponding to the measured pressure.
3. Turn the adjusting screw to the output pressure noted in Step 2. Be sure not to move the slider when turning the screw.

INPUT PRESSURE RANGES
(PSIG EXCEPT WHERE NOTED)

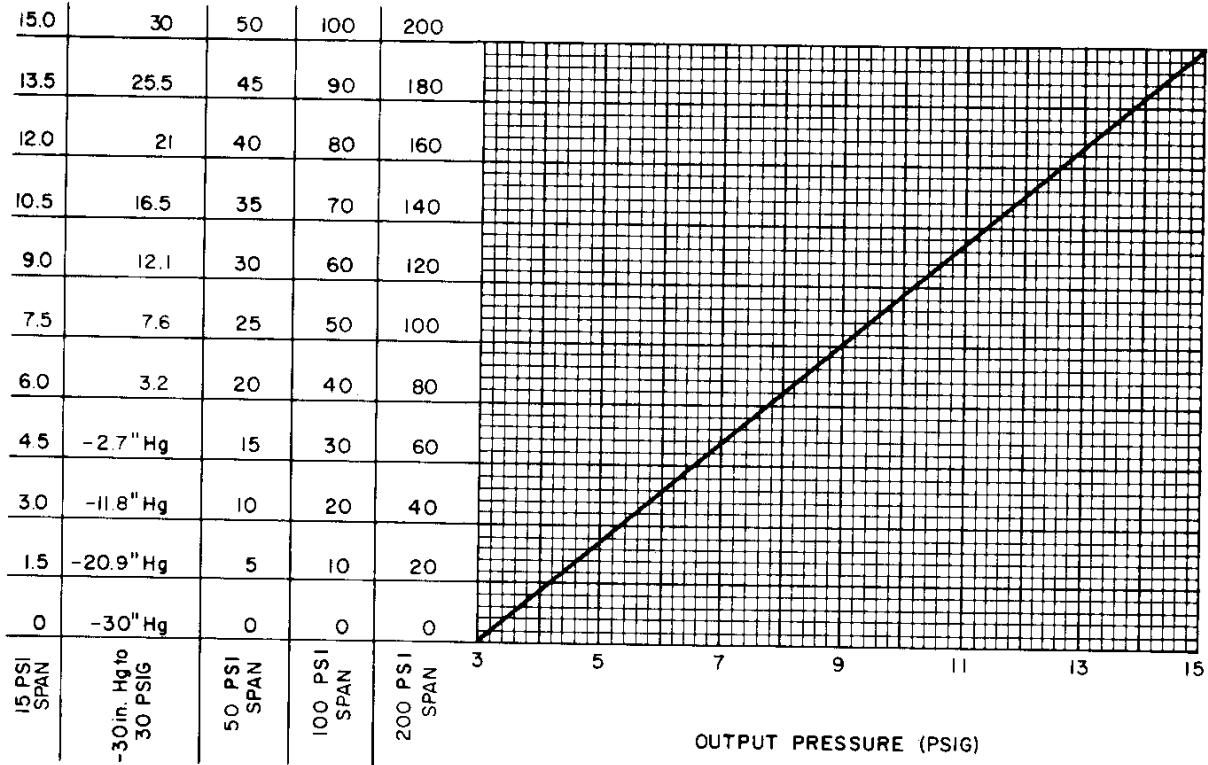

METRIC CONVERSION FACTORS

PSIG x 7 = kPa
in. Hg x 3.38 = kPa

Fig. 5: Input Pressure vs Output Pressure

JOHNSON
CONTROLS

Controls Group
507 E. Michigan Street
P.O. Box 423
Milwaukee, WI 53202

Printed in U.S.A.