

# B212 Technical Data Sheet

## Stainless Steel Ball and Stem

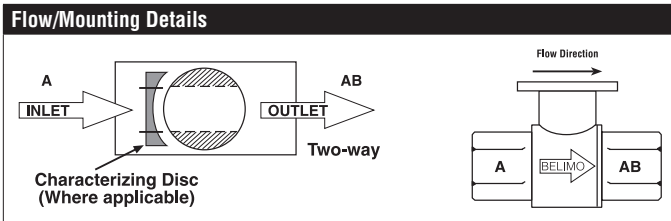

Technical Data	
Fluid	chilled, hot water, up to 60% glycol
Flow characteristic	equal percentage
Controllable flow range	75°
Valve Size [mm]	0.5" [15]
Pipe connection	NPT female ends
Housing	Nickel-plated brass body
Ball	stainless steel
Stem	stainless steel
Stem seal	EPDM (lubricated)
Seat	PTFE
O-ring	EPDM (lubricated)
Characterised disc	TEFZEL®
Body Pressure Rating	600 psi
Close-off pressure Δps	200 psi
Cv	3
Weight	0.66 lb [0.30 kg]
Fluid Temp Range (water)	0...250°F [-18...120°C]
Leakage rate	0% for A – AB
Maintenance	maintenance-free



### Application

This valve is typically used in air handling units on heating or cooling coils, and fan coil unit heating or cooling coils. Some other common applications include Unit Ventilators, VAV box re-heat coils and bypass loops. This valve is suitable for use in a hydronic system with variable flow.

### Suitable Actuators

	Non-Spring	Spring
B212	TR, LRB(X), NR	TFRB(X), LF

### Dimensions (Inches [mm])



A	B	C	D	E	F	H1	H2
9.4" [239]	2.4" [60]	5.6" [141]	5.0" [127]	1.3" [33]		1.2" [30]	1.1" [28]

### Safety Notes

**WARNING:** For Belimo products sold in California: these products do or may contain chemicals which are known to the State of California to cause cancer and or birth defects or other reproductive harms. For more information see [www.p65warnings.ca.gov](http://www.p65warnings.ca.gov).

### Dimensions (Inches [mm])

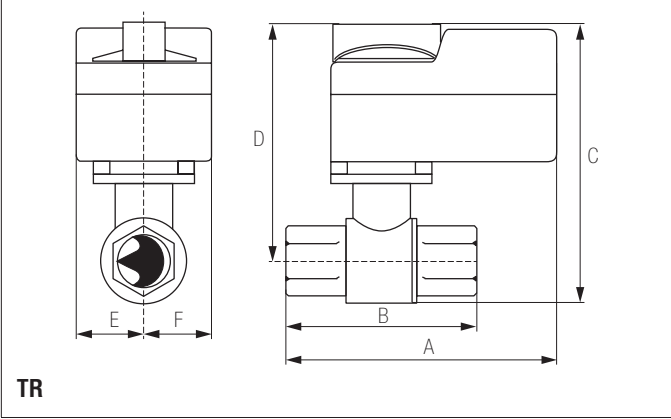

**TR**

A	B	C	D	E	F
3.7" [95]	2.4" [60]	5.2" [132]	4.6" [117]	1.3" [33]	

### Dimensions (Inches [mm])

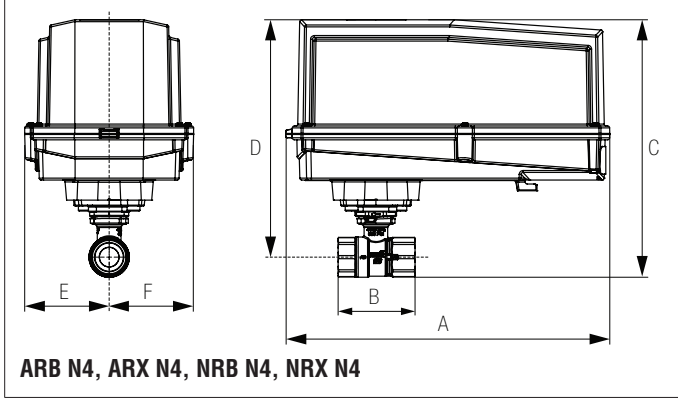

**ARB N4, ARX N4, NRB N4, NRX N4**

A	B	C	D	E	F
11.4" [289]	2.4" [60]	7.7" [196]	7.0" [179]	3.1" [80]	

### Dimensions (Inches [mm])

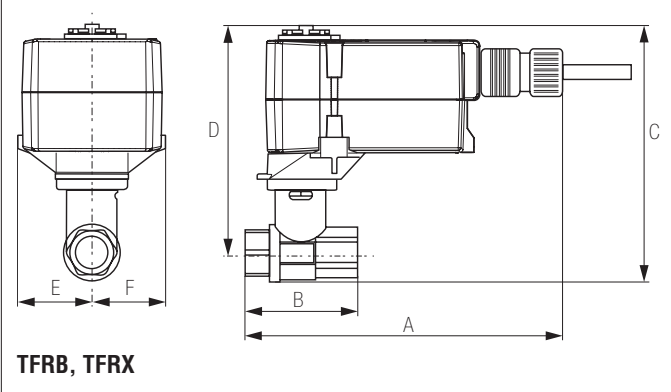

**TFRB, TFRX**

A	B	C	D	E	F
6.6" [167]	2.4" [60]	5.5" [139]	4.7" [120]	1.5" [39]	

### Dimensions (Inches [mm])

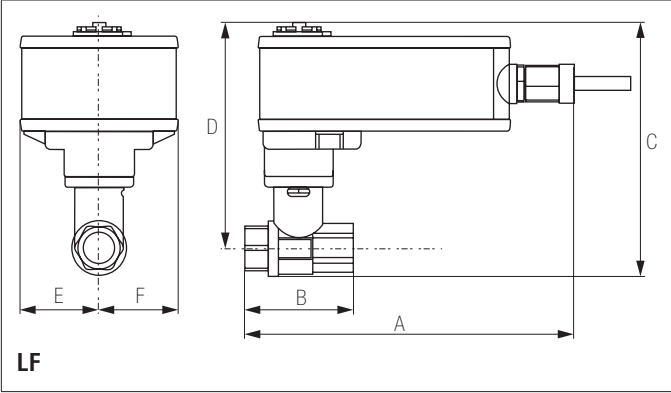

**LF**

A	B	C	D	E	F
7.9" [200]	2.4" [60]	6.1" [154]	5.5" [140]	1.8" [46]	

# LF24-MFT US, Valve Actuator Technical Data Sheet

## Modulating, Spring Return, Multi-Function Technology®



5-year warranty



### Technical Data

Power Supply	24 VAC, ±20%, 50/60 Hz, 24 VDC, ±10%
Power consumption in operation	2.5 W
Power consumption in rest position	1 W
Transformer sizing	5 VA (class 2 power source)
Electrical Connection	18 GA appliance cable, 3 ft [1 m], with 1/2" conduit connector
Overload Protection	electronic throughout 0...95° rotation
Operating Range	DC 2...10 V (default), 4...20 mA w/ ZG-R01 (500 Ω, 1/4 W resistor), variable (VDC, on/off, floating point)
Operating range Y variable	Start point DC 0.5...30 V End point DC 2.5...32 V
Input Impedance	100 kΩ for DC 2...10 V (0.1 mA), 500 Ω for 4...20 mA, 1500 Ω for PWM, On/Off and Floating point
Position Feedback	DC 2...10 V, Max. 0.5 mA, VDC variable
Angle of rotation	90°
Direction of rotation motor	reversible with built-in switch
Direction of motion fail-safe	reversible with cw/ccw mounting
Position indication	Mechanical
Running Time (Motor)	default 150 s, variable 75...300 s
Running time fail-safe	<25 s @ -4...122°F [-20...50°C], <60 s @ -22°F [-30°C]
Ambient humidity	max. 95% r.H., non-condensing
Ambient temperature	-22...122°F [-30...50°C]
Storage temperature	-40...176°F [-40...80°C]
Degree of Protection	IP54, NEMA 2
Agency Listing	cULus acc. To UL 873 and CAN/CSA C22.2 No. 24-93
Noise level, motor	50 dB(A)
Noise level, fail-safe	62 dB(A)
Servicing	maintenance-free
Quality Standard	ISO 9001
Weight	3.1 lbs (1.40 kg.)

†Rated Impulse Voltage 800V, Type of action 1.AA, Control Pollution Degree 3

\*Variable when configured with MFT options.

### Safety Notes

**WARNING:** For Belimo products sold in California: these products do or may contain chemicals which are known to the State of California to cause cancer and or birth defects or other reproductive harms. For more information see [www.p65warnings.ca.gov](http://www.p65warnings.ca.gov).

## Wiring Diagrams

### INSTALLATION NOTES

- Actuators with appliance cables are numbered.
- Provide overload protection and disconnect as required.
- Actuators may be connected in parallel. Power consumption and input impedance must be observed.
- Apply only AC line voltage or only UL-Class 2 voltage to the terminals of auxiliary switches. Mixed or combined operation of line voltage/safety extra low voltage is not allowed.
- Actuators may also be powered by 24 VDC.
- Two built-in auxiliary switches (2x SPDT), for end position indication, interlock control, fan startup, etc.
- Only connect common to negative (-) leg of control circuits.
- A 500 Ω resistor (ZG-R01) converts the 4 to 20 mA control signal to 10 VDC.
- Control signal may be pulsed from either the Hot (Source) or Common (Sink) 24 VAC line.
- For triac sink the Common connection from the actuator must be connected to the Hot connection of the controller. Position feedback cannot be used with a triac sink controller; the actuator internal common reference is not compatible.
- Actuators may be connected in parallel if not mechanically linked. Power consumption and input impedance must be observed.
- IN4004 or IN4007 diode. (IN4007 supplied, Belimo part number 40155).
- Meets cULus requirements without the need of an electrical ground connection.
- Actuators are provided with color coded wires. Wire numbers are provided for reference.
- WARNING! LIVE ELECTRICAL COMPONENTS!** During installation, testing, servicing and troubleshooting of this product, it may be necessary to work with live electrical components. Have a qualified licensed electrician or other individual who has been properly trained in handling live electrical components perform these tasks. Failure to follow all electrical safety precautions when exposed to live electrical components could result in death or serious injury.

**24 VAC Transformer** ◆ (A) 1 3 11

**On/Off**

**24 VAC Transformer (AC Only)** ◆ (A) 1 10 11

**Floating Point**

**24 VAC Transformer** ◆ (A) 1 3 5 11

**VDC/mA Control**

**24 VAC Transformer (AC Only)** ◆ (A) 1 8 11

**PWM Control**

**24 VAC Transformer (AC Only)** ◆ (A) 1 5

Functions	a	b	c
Min	0% ←	↘	↘
Mid	50% ←	↘	↘
Max	100% ←	↘	↘
Normal	Control mode acc. to Y	↘	↘

**Override Control**