

# Ball Valve Assemblies with SmartX Actuators

## Ball Valve Assemblies

The Schneider Electric VA, VF, and VS-2xx3-xxx-9-xx series Ball Valve Assemblies are complete actuator/valve assemblies that accept two-position, floating, or proportional control signals from a DDC system or a thermostat, for control of hot or chilled water, or solutions of up to 50% glycol. They consist of direct-coupled SmartX spring return or non-spring return actuators mounted on 2-way (½" to 3") and 3-way (½" to 2") ball valve bodies.

Typical applications include reheat on VAV boxes, fan coil units, hot and chilled water coils in air handling units, and unit ventilators.

Vx-2xx3-xxx-9-xx series ball valve assemblies are available with either spring return or non-spring return SmartX Actuators.

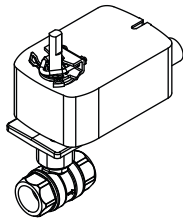

Vx-22x3-5xx-9-xx  
2-Way Assembly with  
Spring Return Actuator

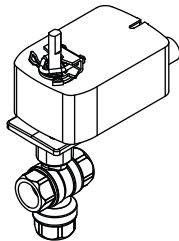

Vx-2313-5xx-9-xx  
3-Way Assembly with  
Spring Return Actuator

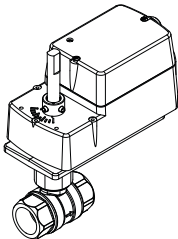

Vx-22x3-8xx-9-xx  
2-Way Assembly with  
Mx4D Series Actuator

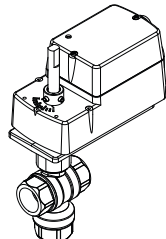

Vx-2313-8xx-9-xx  
3-Way Assembly with  
Mx4D Series Actuator

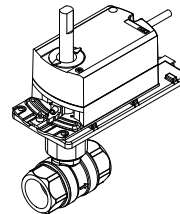

Vx-2213-50x-9-xx  
2-Way Assembly  
with Non-Spring  
Return Actuator

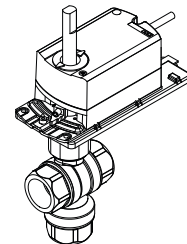

Vx-2313-50x-9-xx  
3-Way Assembly  
with Non-Spring  
Return Actuator

Ball valve body/linkage assemblies allow field mounting of SmartX Actuators.

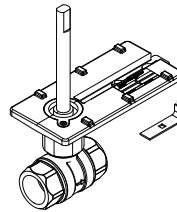

VB-2253-500-9-xx  
Body/Linkage Assembly  
with 2-Way Ball Valve

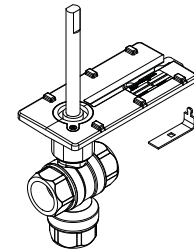

VB-2313-500-9-xx  
Body/Linkage Assembly  
with 3-Way Ball Valve

## Applicable Literature

MA40-704x, MA4x-707x, MA4x-715x Installation Instructions . . . . .	F-26642
MF4x-7xx3, MF4x-7xx3-50x Installation Instructions . . . . .	F-26644
MS4x-7xx3, MS4x-7xx3-50x Installation Instructions . . . . .	F-26645
MF41-6043, MF41-6083 Installation Instructions . . . . .	F-27213
MA4D-xxxx, MF4D-xxxx, MS4D-xxxx Installation Instructions . . . . .	F-27170
MS41-6043, MS41-6083 Installation Instructions . . . . .	F-27214
Mx40-704x Mounting and Wiring Instructions . . . . .	F-27003
Mx4x-6xxx, Mx4x-7xxx, SmartX Actuators Selection Guide . . . . .	F-27986
VA, VF, and VS-2xx3-xxx-9-xx Series Ball Valve Selection Guide . . . . .	F-27086
EN205 Water and Steam Systems . . . . .	F-26080
Schneider Electric Valves and Actuators Catalog . . . . .	F-27855

## Installation

### Inspection

Inspect the package for damage. If damaged, notify the appropriate carrier immediately. If undamaged, open the package and inspect the device for obvious damage. Return any damaged products.

### Requirements

- Tools:
  - #2 Phillips screwdriver
  - 3 mm hex wrench (for setscrew on Mx41-6043 and Mx41-6083 non-spring return actuators)
  - 10 mm socket wrench (for shaft clamp nuts on Mx40-704x spring-return actuators)
  - 10 mm open-end wrench or adjustable wrench such as a Crescent® wrench
  - Torque wrench, range to include 55 to 120 lb-in. (6.2 to 14 N-m)
  - Pipe wrenches, two
  - Additional installation tools as specified in the actuator's installation document
- Training: Installer must be a qualified, experienced technician

#### Notice:

Avoid locations where excessive moisture, vibration, or corrosive fumes are present.

Observe the minimum and maximum temperature limits in "Table 2. Ambient Temperature Limits for Ball Valves Assemblies and Actuators" on page 8.

## General Installation

Table 1. Applicable Actuators for Ball Valves

Valve Size	Actuators	
	Non-Spring Return	Spring Return
½ to 1¼	Mx41-6043 (44 lb-in., 24 Vac) Mx4D-6083 (35 lb-in., 24 Vac)	MA40-7040 (35 lb-in., 120 Vac) Mx40-7043 (35 lb-in., 24 Vac) Mx4D-x0x3
1½ to 3" (2-Way) 1½ to 2" (3-Way)	Mx41-6083 (88 lb-in., 24 Vac)	
½ to 3" (2-Way) and ½ to 2" (3-Way)	Mx4D-6083 (70 lb-in., 24 Vac/20-30 Vdc)	—
½ to 1" (2-Way) and ½ to 1" (3-Way)	—	Mx4D-7033/8033 (30 lb-in., 24 Vac/20-30 Vdc)

## Installation of Mx40-704x Spring Return Actuators

Install the spring return actuator onto the ball valve according to Figure 1.

**NOTE:** Only the 35 lb-in. actuator listed in "Table 1. Applicable Actuators for Ball Valves" on page 2 are compatible with Vx-2x13-5xx-9-xx Ball Valve Assemblies.





**1 For Normally Open 2-Way and Normally Open A to AB 3-Way**

Verify that the valve is in the open position (A to AB open on 3-way valves).

**For Normally Closed 2-Way and Normally Closed A to AB 3-Way**

Verify that the valve is in the closed position (A to AB closed on 3-way valves).

**1** The flats on the sides of the shaft indicate the position of the ball port.

Shaft Style <b>1</b>	2-Way		3-Way Mixing/Diverting	
<b>Current</b> Flats on Sides of Shaft 	 Closed (Fully CW)	 Open (Fully CCW)	 B Full Open to AB (Fully CW)	 A Full Open to AB (Fully CCW)

**2 For Normally Open 2-Way and Normally Open A to AB 3-Way**

Slide the actuator straight down over the valve shaft and onto the mounting plate, with the "L" side facing up. On MS40-7043 models, the rotation switch must be in the "L" position.

**For Normally Closed 2-Way and Normally Closed A to AB 3-Way**

Slide the actuator straight down over the valve shaft and onto the mounting plate, with the "R" side facing up. On MS40-7043 models, the rotation switch must be in the "R" position.

**MX40-704X**

**5** Using a 10 mm wrench or socket, evenly tighten the two nuts on the shaft clamp, applying 8 to 10 lb-ft (11 to 14 N-m) of torque.

**3** Align the actuator with the mounting plate, then slide the anti-rotation clip half way into the slot on the bottom of the actuator.

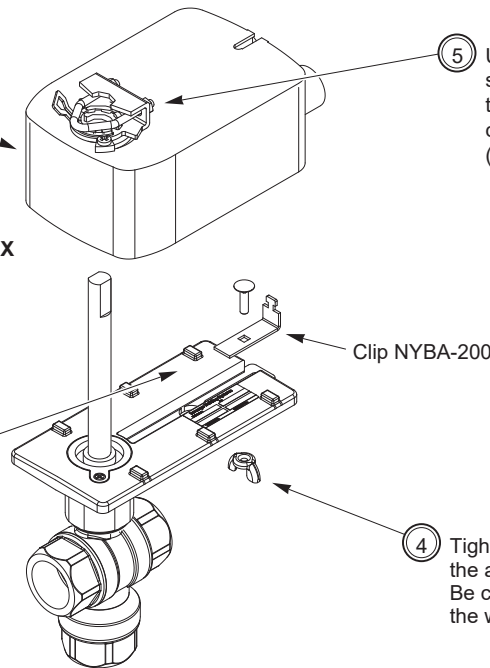

**4** Tighten the wing nut to secure the anti-rotation clip in place. Be careful not to over-tighten the wing nut.









Figure 1. MX40-704x Spring Return Actuator Installation

### Installation of Mx41-6043 and Mx41-6083 Non-Spring Return Actuators

Install the non-spring return actuator onto the ball valve according to Figure 2.

**NOTE:** Only the 44 lb-in. and 88 lb-in. actuators listed in "Table 1. Applicable Actuators for Ball Valves" are compatible with Vx-2x13-5xx-9-xx Ball Valve Assemblies.

- 1 Verify that the valve is open.

Shaft Style <sup>1</sup>	2-Way		3-Way Mixing/Diverting	
Current Flats on Sides of Shaft 	 Inlet  Outlet Closed (Fully CW)	 Inlet  Outlet Open (Fully CCW)	 A  AB B Full Open to AB (Fully CW)	 A  AB A Full Open to AB (Fully CCW)

<sup>1</sup> The flats on the sides of the shaft indicate the position of the ball port.

- 2 Slide the actuator straight down over the valve shaft and onto the mounting plate.

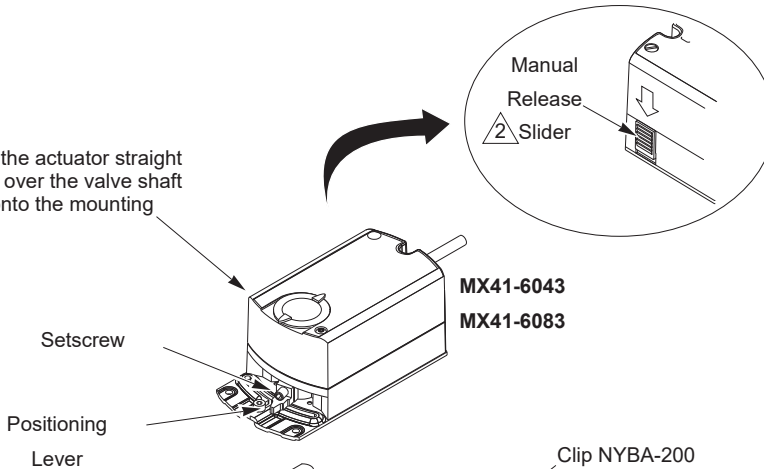

- 3 Align the actuator with the mounting plate, then slide the anti-rotation clip half way into the slot on the bottom of the actuator.

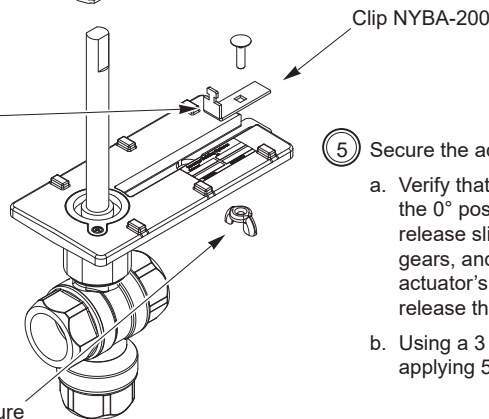

- 4 Tighten the wing nut to secure the anti-rotation clip in place. Be careful not to over-tighten the wing nut.

- 5 Secure the actuator to the valve shaft:
  - a. Verify that the actuator's position indicator is pointing to the 0° position. If it is not, slide and hold the manual release slider on the actuator housing to disengage the gears, and then use the positioning lever to turn the actuator's output shaft to the 0° position. When finished, release the slider or button to re-engage the gears.
  - b. Using a 3 mm hex wrench, tighten the setscrew, applying 55 to 60 lb-in. (6.2 to 6.8 N-m) of torque.

<sup>2</sup> Caution: Only use the manual override when the actuator drive motor is not powered. Engaging the manual override when the actuator is powered will cause damage to the gears.

Figure 2. Installation of Non-Spring Return Actuators on Ball Valve.

**⚠ WARNING**

**DISCONNECT POWER**

- Disable power to the actuator prior to operating the manual override.
- Only use the manual override when the actuator drive motor is not powered. Engaging the manual override when the actuator is powered will cause damage to the gears.

**Failure to follow this instruction may result in equipment damage or personal injury.**









### Installation of Mx4D-x0x3 Spring and Non-Spring Return Actuators

Install the actuator onto the ball valve according to Figure 3.

**NOTE:** Only the 35 lb-in. and 70 lb-in. actuators listed in "Table 1. Applicable Actuators for Ball Valves" are compatible with Vx-2x13-8xx-9-xx Ball Valve Assemblies.

- ① **Spring return and non-spring return models**  
 For normally open 2-Way and normally open A to AB 3-way valves, verify that the valve is open.

**Spring return models**  
 For normally closed 2-Way and normally closed A to AB 3-way valves, verify that the valve is closed.

Shaft Style <sup>1</sup>	2-Way		3-Way Mixing/Diverting	
<b>Current</b> Flats on Sides of Shaft 	 Inlet  Outlet Closed (Fully CW)	 Inlet  Outlet Open (Fully CCW)	 A  AB B Full Open to AB (Fully CW)	 A  AB A Full Open to AB (Fully CCW)

<sup>1</sup> The flats on the sides of the shaft indicate the position of the ball port.

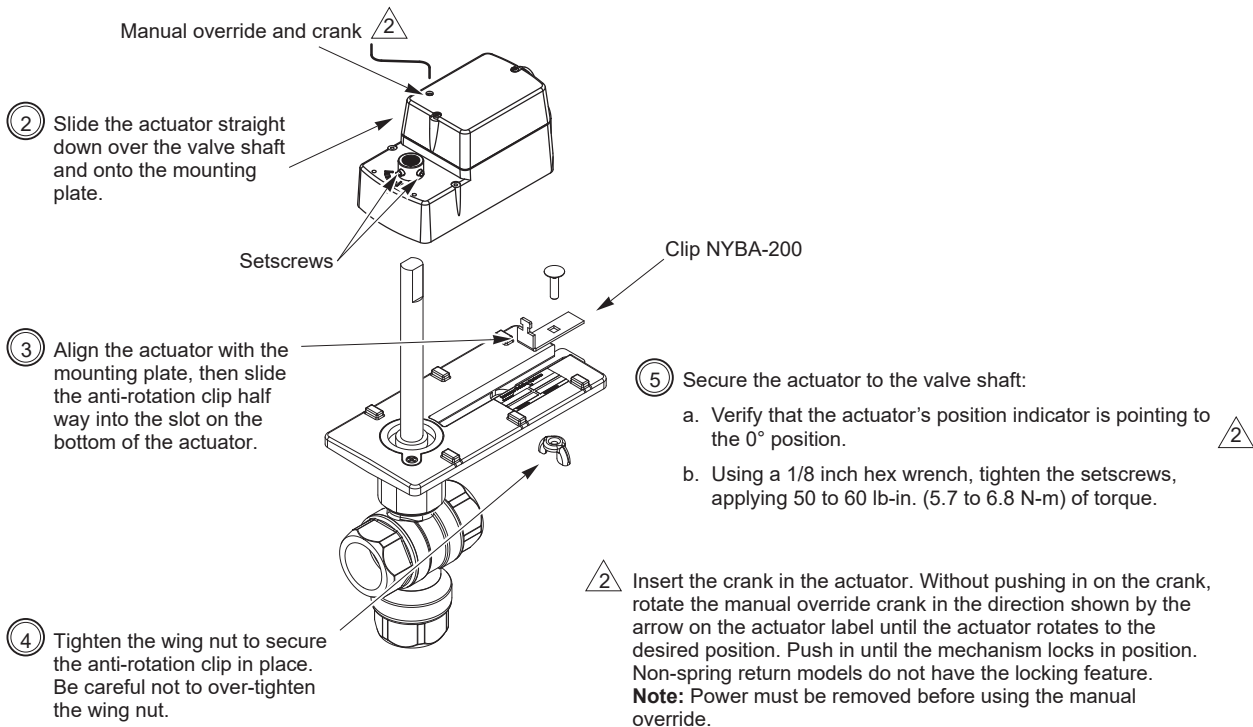

Figure 3. Installation of Mx4D-xxxx-xxx Actuators on Ball Valve.

**⚠ WARNING**

**DISCONNECT POWER**

- Disable power to the actuator prior to operating the manual override.
- Only use the manual override when the actuator drive motor is not powered. Engaging the manual override when the actuator is powered will cause damage to the gears.

**Failure to follow this instruction may result in equipment damage or personal injury.**

### Changing Control Function for MS4D-xxxx (proportional units only)

These actuators are equipped with a jumper to control the function of the signal as received. See Figure 4. The factory setting is for direct acting (actuator moves away from normal position as signal increases). Remove the cover to change jumper settings.

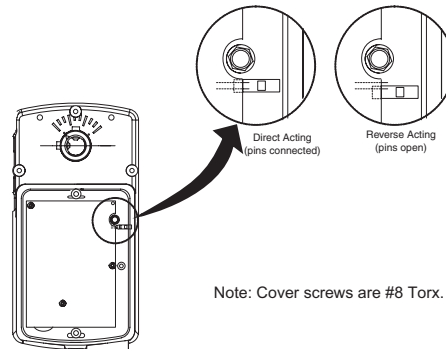

Figure 4. RA/DA Jumper Setting for Proportional Models.

### Changing Control Function for MS40-704x (proportional units only)

The MS40-7043 actuator is equipped with a switch to control the direction of rotation. The switch can be set to "L" (left) or "R" (right) rotation. See Figure 5. An actuator set to "L" will have a clockwise rotation when viewed from the left side. When viewed from the right side the rotation will be counterclockwise.

**NOTE:** These are spring return actuators. It is possible to switch to a direction that moves the actuator against the -5° positive stop. Example: Viewing the actuator from the left side with the switch set to "R" and an increasing signal. The actuator will attempt to rotate beyond the -5° stop and will stall.

#### MS40-704X

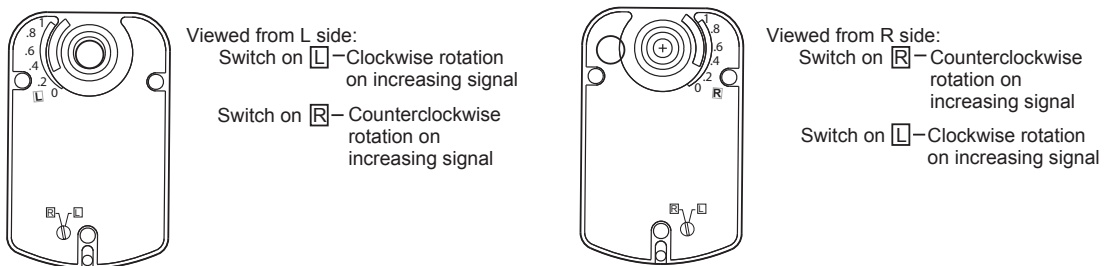

Figure 5. Switch Settings for Proportional MS40-704x Models.

### Changing Control Function for MS41-6083 (proportional units only)

The MS41-6083 actuator uses a dual in-line package (DIP) switch to control the direction of rotation. The DIP is located on a lower corner of the face of the actuator and is covered with a protective cover. Raise the cover to set the DIP. The factory setting is clockwise, as shown in Figure 6. The middle switch controls the rotation. The direction of the rotation switch should match the damper rotation movement.

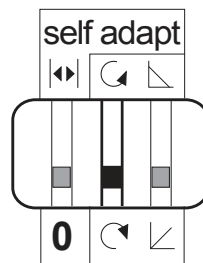
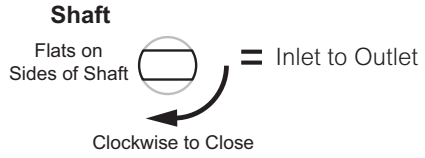
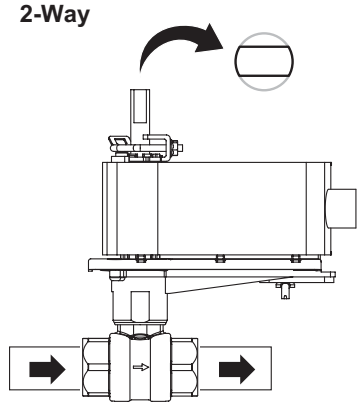

Figure 6. DIP Switch Set for Clockwise Rotation.

# Valve Mounting

## General Piping Practices

Figure 7 illustrates how 2-Way, 3-Way Mixing and 3-Way Diverting ball valve assemblies are to be piped.



- Flats on the sides of the shaft indicate the position of the ball port.
- Characterized 2-way ball valves should be piped in the direction of water flow (labeled with an arrow on one side of the valve body). While it is possible to pipe these ball valves in the opposite direction, doing so will adversely affect the equal percentage flow curves.

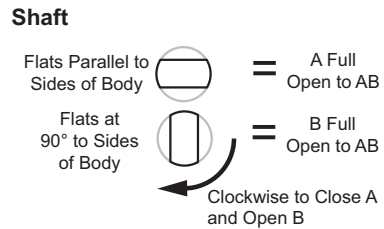
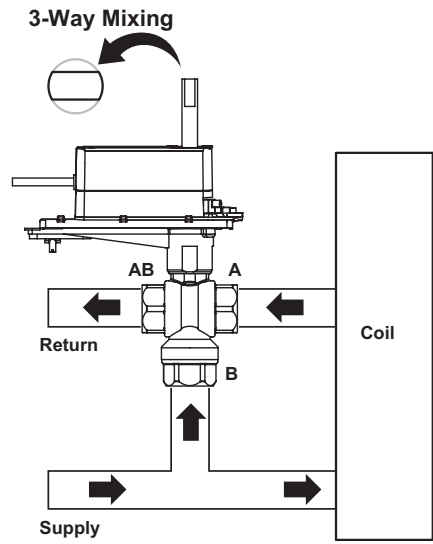

- 3-Way Mixing: Fluid enters through the inlet ports (A and B) and exits through one outlet (port AB).

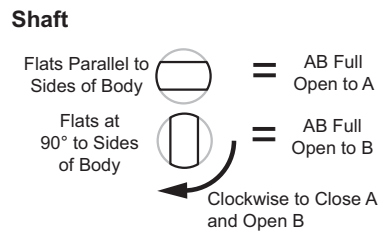
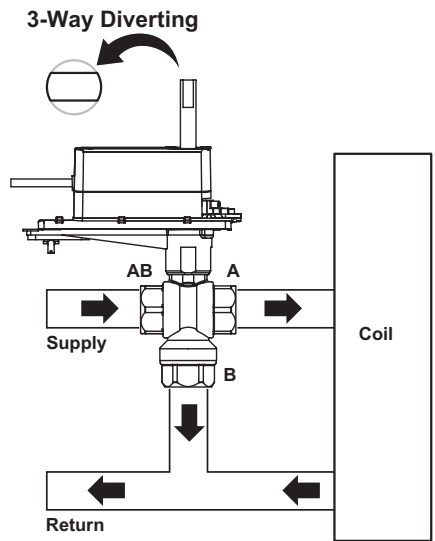

- 3-Way Diverting. Fluid enters through the inlet port AB and exits through one outlet (port A or B)

Figure 7. 2-Way, 3-Way Mixing and 3-Way Diverting Valve Assemblies Piping Diagram.

## Insulation of Ball Valve Assembly

The ball valve should be completely insulated to minimize the effect of heat transfer and condensation at the actuator. The actuator itself must not be insulated. Doing so can result in excess heat or condensation within the actuator.

### Temperature Limits for Ball Valve Assembly

When installing the ball valve assembly, observe the minimum and maximum temperature limits below.

Table 2. Ambient Temperature Limits for Ball Valves Assemblies and Actuators

Ambient Temperature For		Temperature Limits	
		Minimum °F (°C)	Maximum °F (°C)
Mx41-6043	Storage	-40 (-40)	158 (70)
Mx41-6083	Operating	-25 (-32)	130 (55)
Mx40-704x	Storage	-40 (-40)	160 (71)
	Operating	-22 (-30)	140 (60)

### Installation of Ball Valve Assembly

Mount the valve assembly in the piping according to Figure 8.

Notes:

- 2-way ball valves containing characterized inserts must be piped in the direction of the arrow on the side of the valve body.
- 2-way proportional spring return ball valve assemblies are shipped either normally open, voltage rise to close (actuator code 53x), or normally closed, voltage rise to open (actuator code 52x).
- 3-way proportional spring return ball valve assemblies are shipped either A to AB closed, voltage rise to open (actuator code 52x), or A to AB open, voltage rise to close (actuator code 53x).
- All 2-way proportional non-spring return ball valve assemblies are shipped open, voltage rise to close.
- All 3-way proportional spring return ball valve assemblies are shipped A to AB open, voltage rise to close.
- Mount the valve in a weather-protected area, in a location that is within the ambient temperature limits of the actuator.
- When selecting a location, allow sufficient clearance on all sides to allow for any maintenance that may be needed. Refer to Ball Valve Assemblies and Ball Valve Body /Linkage Assemblies Selection Guide, F-27086, for dimensions.
  - Mount the valve assembly so that the actuator is above the horizontal, relative to the valve. This ensures that any condensate that forms on the valve body will not travel into the actuator, where it may cause corrosion or electrical malfunction.

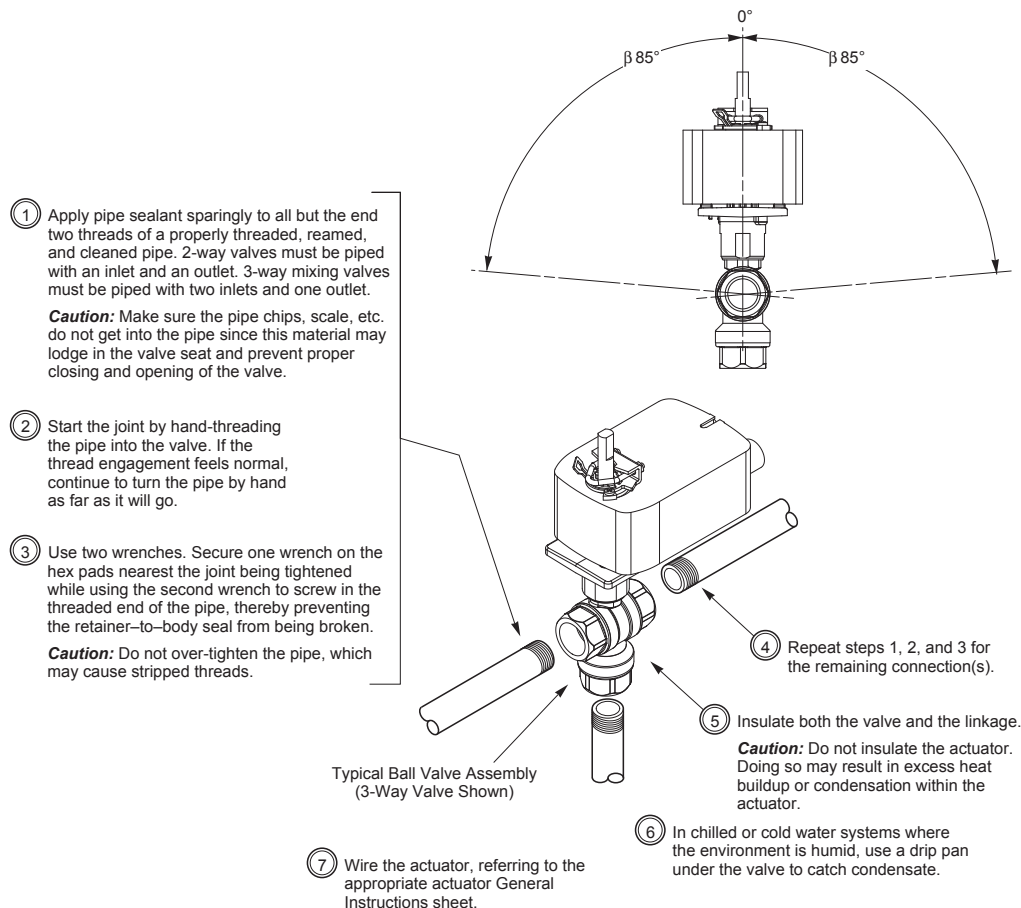
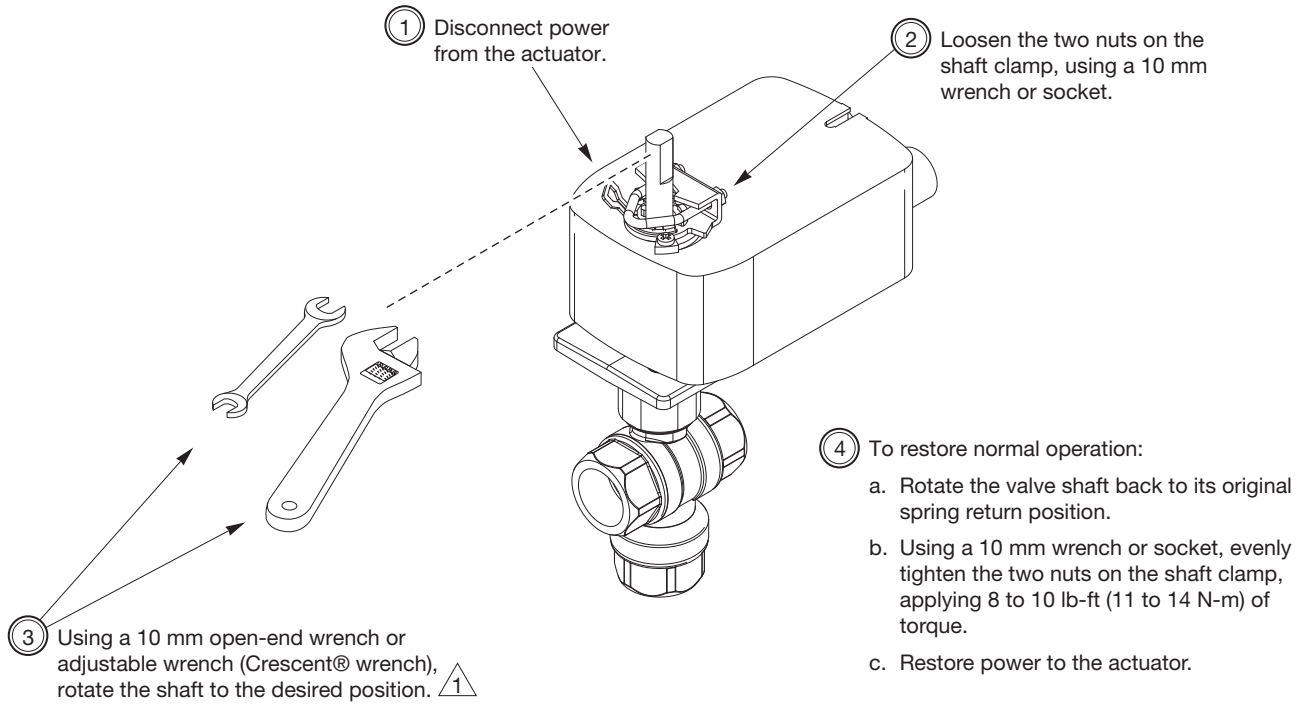

Figure 8. Mounting Ball Valve Assembly in Piping.



### Manual Valve Positioning of Mx40-704x Spring Return Actuators

Before applying power to a ball valve assembly on a new installation, it may be desired to manually open the valve for system filling at startup. Manually open the ball valve assembly according to Figure 9, which shows the valve in the open position.



#### Alternate Method

If the actuator is not yet wired:

- Loosen the wing nut on the underside of the mounting plate, then slide the anti-rotation clip out of the slot on the bottom of the actuator. ⚠
- Turn the actuator to the desired position.
- To restore normal operation, rotate the actuator back into alignment with the mounting plate, then slide the anti-rotation clip half way into the slot on the bottom of the actuator. Tighten the wing nut to secure the anti-rotation clip, being careful not to over-tighten it.

⚠ The flats on the sides of the shaft indicate the position of the ball port.

Flats on Sides of Shaft

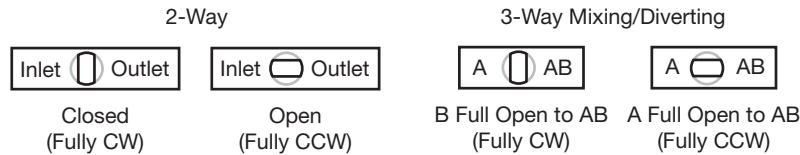

Figure 9. Manually Opening Valve Assemblies Equipped with Mx40-704x Series Actuators.

### Manual Valve Positioning of Mx41-6043 and Mx41-6083 Non-Spring Return Actuators

Before applying power to a ball valve assembly on a new installation, it may be desired to manually open the valve for system filling at startup. Manually open the ball valve assembly according to Figure 10, which shows the valve in the open position.

**NOTE:** The Mx41-6043 and Mx41-6083 series actuators feature a manual override that allows them to be manually positioned for system startup (or emergencies).

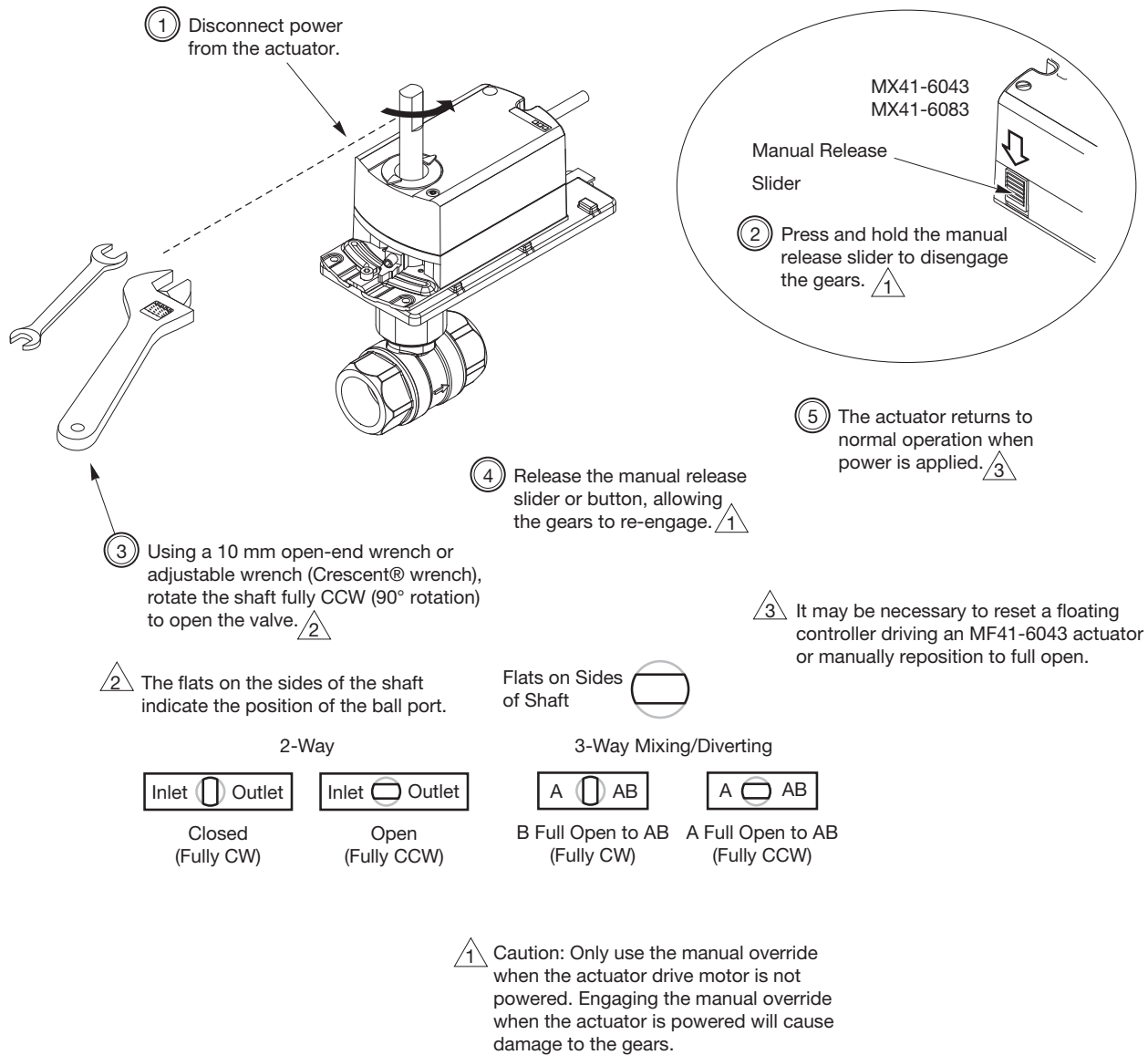

Figure 10. Manually Opening Valve Assemblies Having Mx41-6043 Series Actuators.

<b>⚠ WARNING</b>
<b>DISCONNECT POWER</b>
<ul style="list-style-type: none"> <li>• Disable power to the actuator prior to operating the manual override.</li> <li>• Only use the manual override when the actuator drive motor is not powered. Engaging the manual override when the actuator is powered will cause damage to the gears.</li> </ul>
<b>Failure to follow this instruction may result in equipment damage or personal injury.</b>

## Checkout

Checkout the valve and actuator assembly operations:

1. Power the actuator and run the valve full stroke. The valve stem should operate smoothly. At the closed position, the valve should shut off tightly.
2. For spring return actuators, allow the actuator to spring return to the normal position. Again, the valve stem should operate smoothly.
3. With the piping under pressure, check the valve body and the connections for leaks.

## Maintenance

The ball valve assembly itself requires no maintenance. The stem and packing design eliminates the need for packing adjustment for the life of the valve. However, regular maintenance of the total heating and cooling system is recommended to assure sustained optimum performance.

## Water System Maintenance

All heating and cooling systems are susceptible to valve and system problems caused by improper water treatment and system storage procedures. The following guidelines are to help avoid valve and water system problems resulting from improperly treated water or storage procedures, and to obtain maximum life from Schneider Electric valves.

- To maintain non-damaging conditions, clean the system prior to start up. Use a nitrite or molybdate based treatment program. Use filtration equipment where needed. Properly store off-line systems and monitor water treatment results using corrosion test coupons.
- Durability of valve stems, balls, seats, and packing is dependent on maintaining non-damaging water conditions. Inadequate water treatment or filtration, not in accordance with chemical supplier/ASHRAE handbook recommendations, can result in corrosion, scale, and abrasive particle formation. Scale and particulates can result in stem and packing scratches, and can adversely affect packing life and other parts of the hydronic system.
- Follow the advice of a water treatment professional. Consult EN-205 Water and Steam System Guidelines, Engineering Information, F-26080, for further details.

