

# P66 Series Electronic Fan Speed Controls

## Application

**IMPORTANT:** Use this P66 Series Electronic Fan Speed Control only as an operating control. Where failure or malfunction of the P66 control could lead to personal injury or property damage to the controlled equipment or other property, additional precautions must be designed into the control system. Incorporate and maintain other devices, such as supervisory or alarm systems or safety or limit controls, intended to warn of or protect against failure or malfunction of the P66 control.

The P66 Series Electronic Fan Speed Controls are pressure-actuated electronic motor-speed controllers designed primarily to control condenser fan motors on Heating, Ventilating, Air Conditioning, and Refrigeration (HVAC/R) applications (Figure 1). These controls vary the supply voltage to the fan motor in response to the sensed refrigerant pressure, providing direct response to changes in condenser pressure, regardless of the variations in air delivery curves.

P66 controls are available with one or two pressure sensor inputs. In dual sensor models, the control selects the input with the greatest demand.

P66 control models are also available with NEMA 3R (Rainproof) enclosures for outdoor applications (Figure 1). These models come with a plastic enclosure, appropriate gaskets, and low voltage wire leads for 24 VAC power. In addition, the critical high voltage components are encapsulated in a potting compound.

**Note:** NEMA 1 models **cannot** be retrofitted in the field to obtain the NEMA 3R (Rainproof) rating.

A P66 and speed controlled motor can replace On/Off fan cycling controls, multiple speed motors, condenser flood-back systems, temperature fan-speed controls, and modulating louver systems.

Typical applications include:

- computer room air conditioning
- commercial air conditioning
- commercial refrigeration

The P66 Series controls must be applied only to single-phase motors intended for use with a solid-state motor speed control. An applicable motor must be a single-phase, permanent split-capacitor motor and must be:

- ball-bearing construction only (Sleeve-bearing motors are not acceptable for use with P66 controls.)
- designed to handle non-sinusoidal waveforms generated by solid-state motor speed controls
- designed to dissipate the motor heat generated at reduced speed operation

 **CAUTION: Risk of Property Damage**  
Use only single-phase Permanent Split-Capacitor (PSC) motors approved by the manufacturer for speed control applications with the P66 control. Failure to use a single-phase PSC motor may damage the motor and other property.

## Installation

 **WARNING: Risk of Personal Injury**  
Do not install the P66 Electronic Fan Speed Control in any application using corrosive or flammable refrigerants. The P66 control is not designed or intended for use with those refrigerants. Use of the P66 control with corrosive or flammable refrigerants may lead to release of refrigerant, which could cause property damage, fire, severe personal injury or death.

## Dimensions

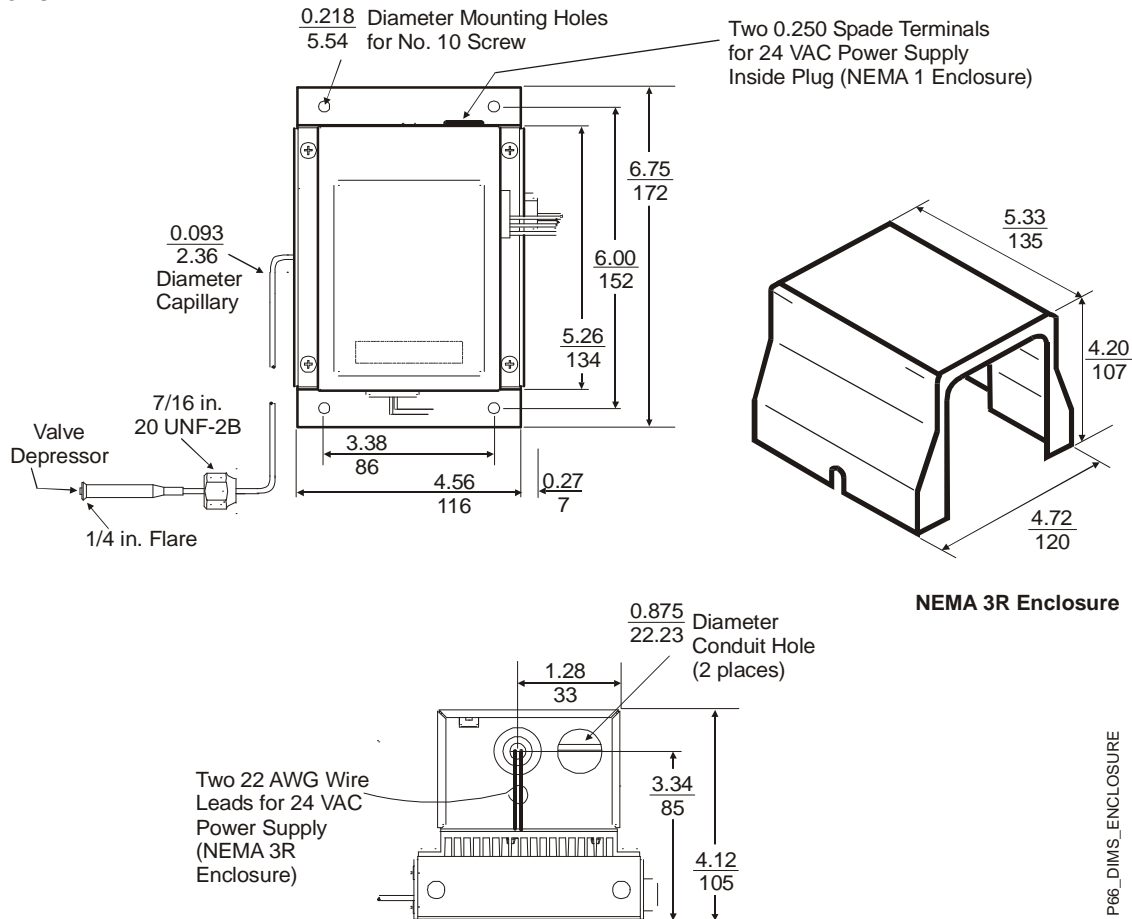

Figure 1: P66 Control and NEMA 3R Enclosure Dimensions, in./mm

## Mounting

Observe the following guidelines when mounting a P66 control and routing the control's capillary tube:



### CAUTION: Risk of Environmental and Property Damage

Coil and secure excess capillary tubing away from contact with sharp or abrasive objects or surfaces. Vibration or sharp or abrasive objects in contact with capillary tubes can cause damage that may result in refrigerant leaks or loss of element charge which may result in damage to the environment or property.



### CAUTION: Risk of Environmental and Property Damage

Avoid sharp bends in the capillary tubes. Sharp bends can weaken or kink capillary tubes which may result in refrigerant leaks or restrictions of flow.

- Maintain operating pressures and temperatures within the listed product ratings to assure reliable operation. See *Technical Specifications* table.
- Mount the P66 control away from sources of excessive heat.
- Mount the P66 control with the cooling fins in a vertical position with no obstruction preventing airflow through the fins.
- Locate the P66 control where fan air passes through the cooling fins to maximize heat dissipation.
- Locate the P66 control so the pressure elements inside the base are above the refrigerant liquid level of the controlled equipment.
- Mount the control where it can be conveniently wired to the power supply and the motor.
- Provide the recommended pressure connection in the high-pressure vapor line near the condenser inlet. (A 60 in. capillary is standard.)

- Evacuate all tubing and lines before connecting the P66 control.

**Note:** A Schrader® valve depressor is provided with the female flare fitting on standard P66 control models.

## Wiring



### WARNING: Risk of Electric Shock

Disconnect power supply before making electrical connections. Contact with components carrying hazardous voltage can cause electric shock and may result in severe personal injury or death.



### WARNING: Risk of Electric Shock

Ground the P66 Series Electronic Fan Speed Control according to local, national, and regional regulations. Failure to ground the P66 control may result in electric shock and severe personal injury or death.

**IMPORTANT:** Use copper conductors only. Make all wiring connections in accordance with the National Electrical Code and local regulations. Do not exceed the P66 Series Electronic Fan Speed Control's electrical ratings.

The P66 control must be supplied with 24 VAC (1 VA) from an external transformer powered from the same phase as the motor circuit (Figure 2, Figure 3, and Figure 4). The low voltage input connections are 1/4 in. quick-connect terminals on the NEMA 1 models and two 6 in. 22 AWG wires on the NEMA 3R models. The line voltage connections are 10-32 screw terminals.

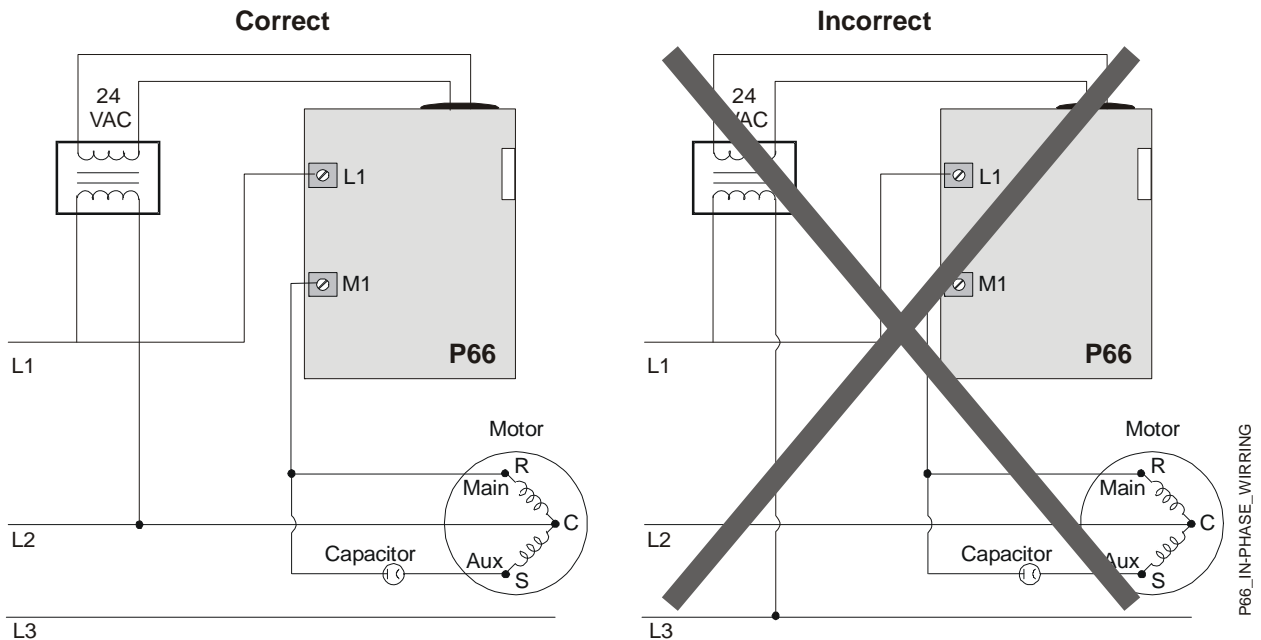

**Figure 2: Permanent Split-Capacitor Motor Connections to the P66 Fan Speed Control (The 24 VAC power supply must be connected in-phase with the motor power supply.)**

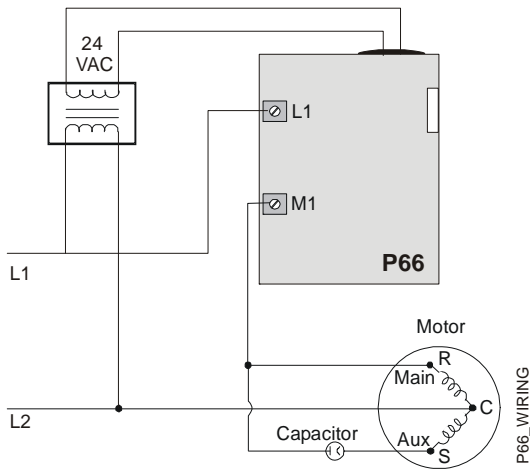

**Figure 3: Permanent Split-Capacitor Motor Connections to the P66 Fan Speed Control**

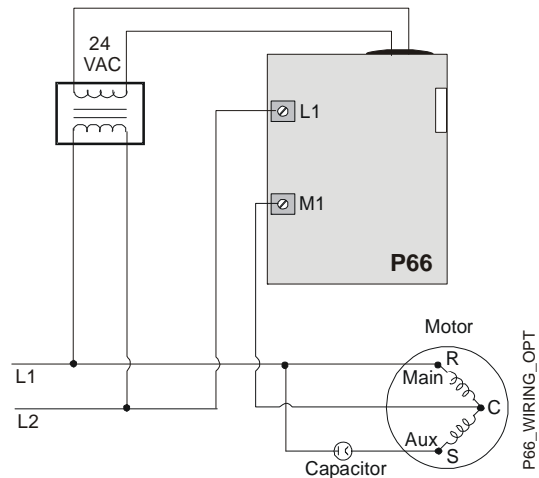

**Figure 4: Optional Wiring Diagram for Permanent Split-Capacitor Motor Connections to the P66 Fan Speed Control**

## Setup and Adjustments

The P66 control's throttling range is fixed and cannot be adjusted. The operating range pressure is adjustable within the control pressure range. See the *Technical Specifications* table for P66 model pressure ratings.

To adjust the operating range pressure:

1. Apply a reliable pressure gauge to the controlled system to monitor the pressure adjustments.
2. Access the operating range adjustment screw for the P66 pressure transducer through the opening in the upper left-hand corner of the P66 control base (Figure 5).

**Note:** On dual pressure models, access to the second adjustment screw is located in the lower right-hand corner of the control base.

3. Turn the adjustment screw 1/2 turn (or less) clockwise to increase the operating range pressure or 1/2 turn (or less) counterclockwise to decrease the operating range pressure.
  - **Low Pressure Models (80 to 200 psig):**  
1/2 turn = approximately  $\pm 9$  psig (62 kPa)
  - **Medium Pressure Models (140 to 350 psig):**  
1/2 turn = approximately  $\pm 18$  psig (124 kPa)
  - **High Pressure Models (300 to 500 psig):**  
1/2 turn = approximately  $\pm 35$  psig (241 kPa)

**IMPORTANT:** Do not adjust the operating range screw more than 1/2 turn before allowing the system pressure to stabilize.

4. Check system pressure and repeat Step 3 until the desired operating range pressure is attained.

**CAUTION: Risk of Property Damage**  
Limit any adjustments to two full turns in either direction. Over-adjustment may prohibit modulation of the motor resulting in high head pressures. All pressure adjustments should be verified with the use of refrigerant pressure gauges.

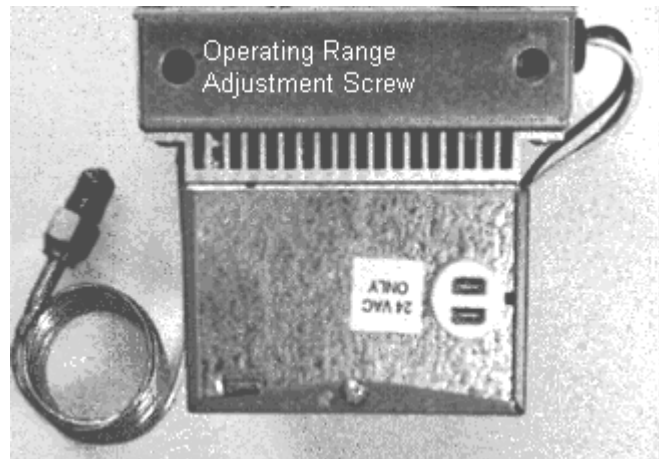

**Figure 5: Operating Range Adjustment Screw Location**

### Checkout

Before leaving the installation, observe working application for correct operation. See the *Operation* section for a typical operational sequence.

## Operation

Condensing unit installation, operation, and maintenance determine the overall capability of maintaining a satisfactory pressure by means of fan speed control. Within the operating range, the P66 control provides air delivery in direct proportion to heat rejection requirements. This allows the refrigeration system to perform efficiently in very low ambient temperatures.

The P66 pressure transducer provides direct response to changes in condenser pressure, regardless of the variations in fan delivery curves. The dual input models select the pressure input from the transducer sensing the highest pressure.

See Figure 6 for a typical operational sequence for a P66 control.

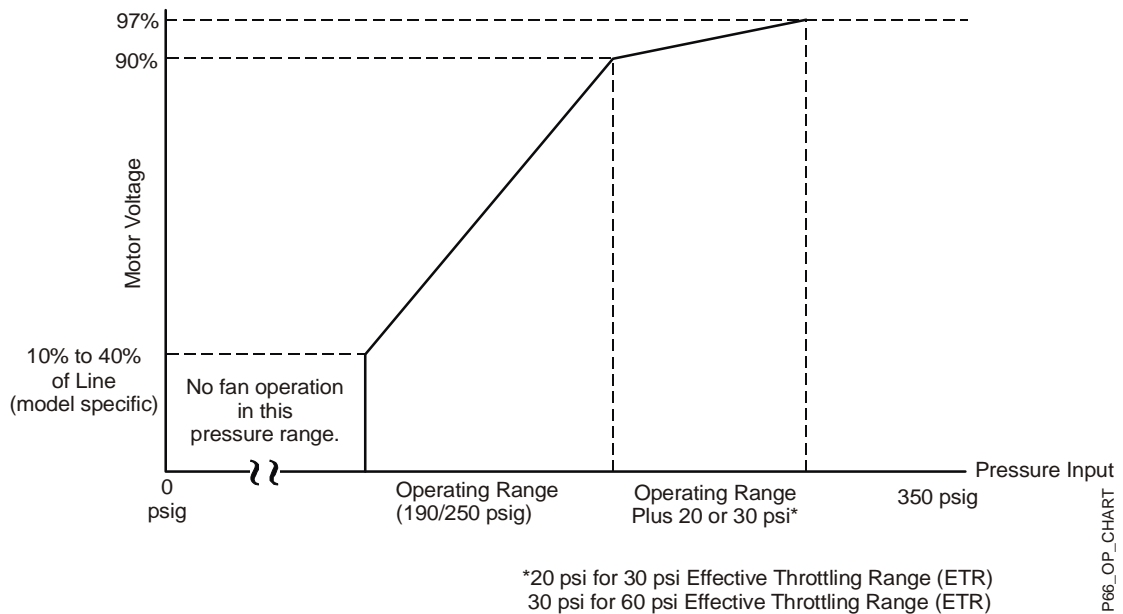

**Figure 6: Operation Chart for the P66 Fan Speed Control**

**Table 1: P66 Control Operation**

Pressure Input	Motor Voltage (VAC, true RMS)
Pressure is between 0 psig and the low end of the operating range.	0 to 5 volts
Pressure is at the low end of the operating range.	Start voltage (10% to 40% of line - model specific)
Pressure is in the operating range.	Motor voltage varies directly with system pressure from start voltage to 90% of line voltage.
Pressure is above the operating range.	A further pressure increase of 20 to 30 psi will increase motor voltage to 97% of the applied voltage.

## Troubleshooting

Refer to the *Operation* section for proper operation.

**Table 2: Troubleshooting Chart**

<b>Problem</b>	<b>Possible Cause</b>	<b>Possible Solution</b>
<b>No Fan Operation</b>	Input pressure is below operating range.	No problem, normal operation.
	No 24 volt control voltage	Check for 24 VAC at control.
	No input pressure to control	Alignment. Schrader valve depressor must depress Schrader valve enough to allow pressure into capillary.
	Bad fan motor	Disconnect power. Place a jumper from L <sub>1</sub> to M <sub>1</sub> and connect power. If fan does not start, motor is bad and should be replaced.
	Pressure transducer problem	See <i>Pressure Transducer Troubleshooting</i> section.
<b>Fan stops when pressure reaches the high end of the operating range.</b>	Control is not wired correctly.	See wiring diagrams. Ensure that the 24 VAC power supply is connected in-phase with the motor power supply.
<b>No Fan Modulation (On-Off Operation)</b>	Control is not wired correctly.	See wiring diagrams. Ensure that the 24 VAC power supply is connected in-phase with the motor power supply.
	Pressure transducer problem	See <i>Pressure Transducer Troubleshooting</i> .
<b>Fan Starts at Full Speed.</b>	Control is not wired correctly.	See wiring diagrams. Ensure that the 24 VAC power supply is connected in-phase with the motor power supply.
	Pressure transducer problem	See <i>Pressure Transducer Troubleshooting</i> .
<b>Erratic Fan Operation</b>	Control is not wired correctly.	Check to see if control voltage (24 VAC) is on same phase as motor.
	Dirty or blocked condenser coil	Clean condenser coil.
	Pressure transducer problem	See <i>Pressure Transducer Troubleshooting</i> .
<b>Fan motor is cycling thermal overload.</b>	Dirty or blocked condenser coil	Clean condenser coil.
	Wrong motor for fan speed control application	Replace with motor approved for fan speed control application.

### Pressure Transducer Troubleshooting

1. Disconnect 6-pin connector from right side of control.
2. Place a jumper wire between third pin from the top and the bottom pin on the control, not the cable.
  - a. If fan goes to full speed, check for input pressure.
  - b. If there is adequate pressure, the transducer is bad and the control must be replaced.

### Repairs and Replacement

Field repairs must not be made. For a replacement control, contact the Original Equipment Manufacturer or your local Johnson Controls/PENN distributor.

## Ordering Information

**Table 3: P66 Control Specific Model Information**

Product Code Number	Operating Range (psig)	Start Voltage (% of Supply Voltage)	Capillary Length (in.)
<b>Single Input Sensor Models</b>			
P66AAB-1	190/250	10	60
P66AAB-4	135/165	10	60
P66AAB-6	170/230	16	60
P66AAB-9	170/230	40	60
P66AAB-10	190/250	16	120
P66AAB-11	140/200	16	60
P66AAB-14	220/280	40	120
P66AAB-15	190/250	40	60
P66AAD-1*	160/220	25	60
P66ABB-21 <sup>+</sup>	220/280	16	120
P66AAB-34	320/410	40	60
<b>Dual Input Sensor Models</b>			
P66BAB-1	190/250	10	60
P66BAB-3	170/230	16	60
P66BAB-4	190/250	16	120
P66BAB-5	190/250	40	60
P66BAD-1*	160/220	25	60
All models are rated for 208-240/277/480 volt; 60Hz except those with Product Code Numbers followed by an asterisk. * 50 Hz Models + Models with NEMA 3R Enclosure			

For further information on model specifications and options, please contact Johnson Controls Application Engineering at 1-800-275-5676.

## Technical Specifications

<b>Product</b>	P66 Series Electronic Fan Speed Controls			
<b>Pressure Ratings</b>	<b>Low Pressure Models</b>	<b>Medium Pressure Models</b>	<b>High Pressure Models</b>	
<b>Control Range</b>	80 to 200 psig (552 to 1379 kPa)	140 to 350 psig (965 to 2413 kPa)	300 to 500 psig (2048 to 3447 kPa)	
<b>Effective Throttling Range</b>	30 psi (207 kPa)	60 psi (414 kPa)	90 psi (621 kPa)	
<b>Maximum Working Pressure</b>	200 psig (1379 kPa)	350 psig (2413 kPa)	500 psig (3447 kPa)	
<b>Maximum Overpressure</b>	250 psig (1724 kPa)	400 psig (2758 kPa)	695 psig (4792 kPa)	
<b>Control Voltage</b>	24 VAC, 1VA			
<b>Line Voltage Range</b>	208 to 480 VAC			
<b>Start Voltage</b>	10% to 40% of line (OEM specified - model specific)			
<b>Electrical Ratings</b>	<b>208 VAC</b>	<b>240 VAC</b>	<b>277 VAC</b>	<b>480 VAC</b>
<b>Full Load Amperes</b>	8.0	8.0	6.9	4.0
<b>Locked Rotor Amperes</b>	16.5	16.5	14.3	10.5
<b>Ambient Temperature Maximum</b>	130°F/54°C	130°F/54°C	130°F/54°C	150°F/66°C
<b>Ambient Temperature Minimum</b>	-40°F/-40°C (at all Voltages)			
<b>Ambient Storage Temperature</b>	-40°F/-40°C to 185°F/85°C			
<b>Construction</b>				
<b>Control Case</b>	Galvanized steel case and cover			
<b>Base and Sensors</b>	Galvanized steel			
<b>Plastic Enclosure</b>	UV stabilized polycarbonate with closed cell foam gasket (NEMA 3R models only)			
<b>Enclosure</b>	NEMA 1 or NEMA 3R (Rainproof)			
<b>Wiring Connections</b>				
<b>Low Voltage</b>	1/4 in. quick connects (NEMA 1); Two 6 in. 22 AWG Wire Leads (NEMA 3R)			
<b>Line Voltage</b>	10-32 Screw Terminals			
<b>Pressure Connections</b>	60 in./1524 mm or 120 in./3048 mm copper capillary with 1/4 in./6 mm flare nut and Schrader valve depressor			
<b>Mounting</b>	Vertical only; two holes for No. 10 screws at the top and bottom			
<b>Agency Listings</b>	UL Recognized (U.S.): File SA516, Guide SDFY2 UL Recognized (Canada): File SA516, Guide SDFY8 CSA Certified: File LR 948, Class 1222 01 - Specific models only. Contact Johnson Controls Application Engineering at 1-800-275-5676 for specific model information.			

The performance specifications are nominal and conform to acceptable industry standards. For application at conditions beyond these specifications, contact Johnson Controls Application Engineering at 1-800-275-5676. Johnson Controls, Inc. shall not be liable for damages resulting from misapplication or misuse of its products.



**Building Efficiency**  
507 E. Michigan Street, Milwaukee, WI 53202

Metasys® and Johnson Controls® are registered trademarks of Johnson Controls, Inc. All other marks herein are the marks of their respective owners. © 2009 Johnson Controls, Inc.