

TC3X21 Small-Sized Basic Defrost Controller Installation Guide

Basic controller for refrigerated cabinets, with energy-saving strategies



- E ENGLISH**
- Controller for normal temperature units
 - Power supply for TC3X21N5x: 115 VAC
 - Power supply for TC3X21N7x: 230 VAC
 - Cabinet probe with a negative temperature coefficient (NTC)
 - Door switch or multi-purpose input
 - Cooling or heating operation

1 MEASUREMENTS AND INSTALLATION

Measurements in mm (inches). Fit the controller to a panel with the snap-in brackets supplied.

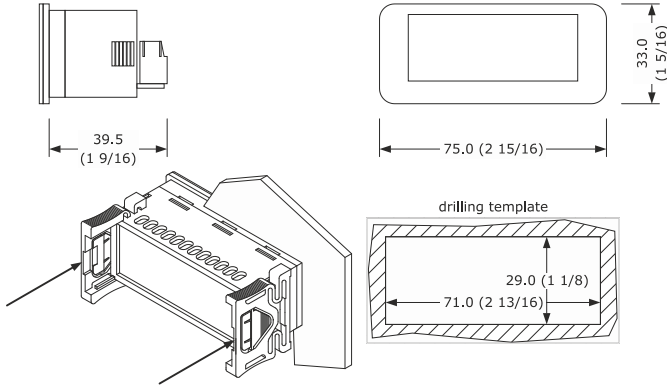

- INSTALLATION PRECAUTIONS**
- Ensure that the thickness of the panel is between 0.8 mm and 2.0 mm (1/32 and 1/16 in)
 - Ensure that the working conditions are within the limits stated in the *TECHNICAL SPECIFICATIONS* section.
 - Do not install the device close to heat sources, equipment with a strong magnetic field, in places subject to direct sunlight, rain, damp, excessive dust, mechanical vibrations or shocks.
 - In compliance with safety regulations, install the device correctly to ensure adequate protection from contact with electrical parts. Fix all protective parts in such a way so as to need the aid of a tool to remove them.

2 ELECTRICAL CONNECTION

- Important**
- Use cables of an adequate wire gauge for the current running through them.
 - To reduce any electromagnetic interference, connect the power cables as far away as possible from the signal cables.

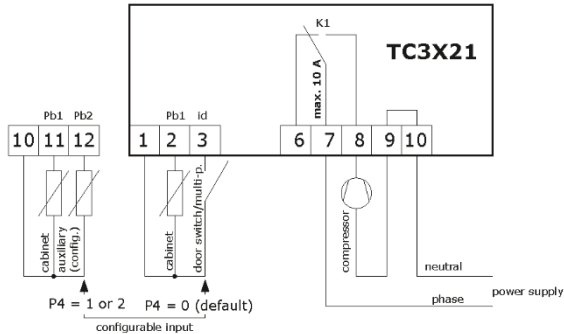

- Power supply for TC3X21N5x: 115 VAC.
- Power supply for TC3X21N7x: 230 VAC.

- PRECAUTIONS FOR ELECTRICAL CONNECTION**
- If you use an electrical or pneumatic screwdriver, adjust the torque to a maximum of 0.5 N•m (4 in. lb).
 - If you move the device from a cold to a warm place, the humidity may cause condensation to form inside. Wait an hour before you switch on the power.
 - Make sure that the supply voltage, electrical frequency, and power are within the set limits. See *TECHNICAL SPECIFICATIONS*.
 - Disconnect the power supply before you do any type of maintenance.
 - Do not use the device as safety device.
 - For repairs and further information, contact the Penn sales network.

3 FIRST-TIME

- Follow the instructions in MEASUREMENTS AND INSTALLATION to install the controller.
- Power up the device as shown in *ELECTRICAL CONNECTION* and an internal test runs. The test normally takes a few seconds. When it finishes the display switches off.
- Configure the device as shown in Table 6.1 in *SETTINGS*.

For recommended configuration parameters for first-time use, see the following table.

PAR.	DEF.	PARAMETER	MIN. - MAX.
SP	32	Setpoint	r1 to r2
P2	1	Temperature unit of measurement	0 = °C 1 = °F

- Check that the remaining settings are appropriate; see *CONFIGURATION PARAMETERS*.
- Disconnect the device from the mains.
 - Make the electrical connection as shown in *ELECTRICAL CONNECTION* without powering up the device.
 - Power up the device.

4 USER INTERFACE AND MAIN FUNCTIONS

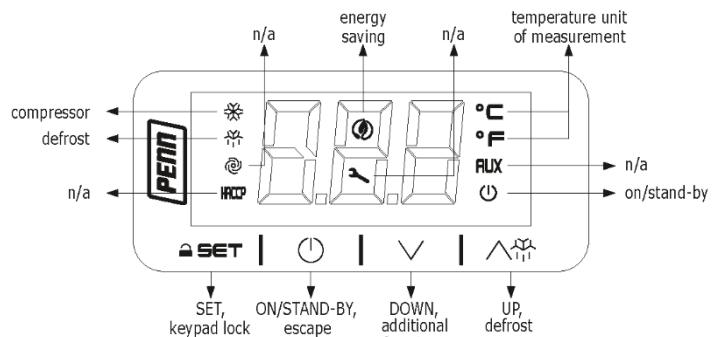

- 4.1 Switching the device on or off**
- If POF = 1, tap the ON/STAND-BY key for 4 s.
- If the device is switched on, the display shows the P5 value, cabinet temperature by default. If the display shows an alarm code, see *ALARMS*.

LED	ON	OFF	FLASHING
☀	Compressor on	Compressor off	- Compressor protection active - Setpoint setting active
☁	Defrost active	-	Dripping active
⚡	- If device on, energy saving active - If device off, low consumption active	-	-
°C/°F	View temperature	-	-
⏻	Device off	Device on	Device on or off active

If 30 s elapse and you do not press the keys, the display shows the "Loc" label and the keypad locks automatically.

- 4.2 Unlocking the keypad**
- Tap any key for 1 s. The display shows the label "UnL".

- 4.3 Setting the setpoint**
- Check that the keypad is not locked.
- Tap the SET key.
 - Tap the UP or DOWN key within 15 s to set the value within the limits r1 and r2.
 - Tap the SET key or do not operate for 15 s.

- 4.4 Activating manual defrost (if r5 = 0, default)**
- Check that the keypad is not locked.
- Tap the UP key for 2 s.
- If P4 = 1, the defrost activates if the evaporator temperature is lower than the d2 threshold.

5 ADDITIONAL FUNCTIONS

- 5.1 Navigating the additional functions menu**
- Before you begin, check that the keypad is not locked.
- To access the additional functions menu, tap the DOWN key for 4 s.
 - To navigate to a label, tap the UP or DOWN key within 15 s.
 - To select a label, tap the SET key.
 - If you cannot edit the parameter, the value displays. If you can edit the parameter, tap the UP or DOWN key to navigate to the value that you want.
 - To set the parameter value, tap the SET key.
 - To exit the procedure, tap the ON/STAND-BY key, or do not operate the controller for 60 s.

5.2 Additional functions menu

Use the additional functions menu to cycle through the labels in the following table.

LABEL	DESCRIPTION
Pb1	Cabinet temperature
Pb2	Auxiliary temperature

6 SETTINGS

- 6.1 Setting configuration parameters**
- Tap the SET key for 4 s. The display shows the label "PA".
 - Tap the SET key.
 - Tap the UP or DOWN key within 15 s to set the password.
 - Tap the SET key or do not operate for 15 s. The display shows the label "SP".
 - Tap the UP or DOWN key to select a parameter.
 - Tap the SET key.
 - Tap the UP or DOWN key within 15 s to set the value.
 - Tap the SET key or do not operate for 15 s.
 - Tap the SET key for 4 s, or do not operate for 60 s, to exit the procedure.

6.2 Restoring the default factory settings and storing customized settings as default

- Important**
- Check that the factory settings are appropriate; see *CONFIGURATION PARAMETERS*.
 - When you store customized settings, you overwrite the default.

- Tap the SET key for 4 s. The display shows the label "PA".
 - Tap the SET key.
 - Tap the UP or DOWN key within 15 s to set the value.
- | VAL. | DESCRIPTION |
|------|---------------------------------------|
| 149 | Restores the default factory settings |
| 161 | Stores customized settings as default |
- Tap the SET key or do not operate for 15 s. The display shows the label "dEF" when you set the value "149" or the label "MAP" when you set the value "161".
 - Tap the SET key.
 - Tap the UP or DOWN key within 15 s to set "4".
 - Tap the SET key or do not operate for 15 s. The display shows "- - -" flashing for 4 s, then the device exits the procedure.
 - Interrupt the power supply to the device.
 - Tap the SET key 2 s before step 6. to exit the procedure beforehand.

7 CONFIGURATION PARAMETERS

PAR.	DEF.	SETPOINT	MIN. - MAX.
SP	32	Setpoint	r1 to r2
ANALOG INPUTS			
PAR.	DEF.	ANALOG INPUTS	MIN. - MAX.
CA1	0	Cabinet probe offset	-25°F/°C to 25°F/°C
CA2	0	Auxiliary probe offset	-25°F/°C to 25°F/°C
P0	1	Probe type	0 = n/a 1 = NTC
P1	1	Enable °C decimal point	0 = No 1 = Yes
P2	1	Temperature unit of measurement	0 = °C 1 = °F
P4	0	Configurable input function	0 = Door switch or multi-purpose input 1 = Evaporator probe 2 = Condenser probe
P5	0	Value displayed	0 = Cabinet temperature 1 = Setpoint 2 = Auxiliary temperature
P8	5	Display refresh time	0 s to 250 s : 10

PAR.	DEF.	CONTROL	MIN. - MAX.
r0	4	Setpoint differential	1°F/°C to 15°F/°C
r1	-50	Minimum setpoint	-99°F/°C to r2
r2	100	Maximum setpoint	r1 to 199°F/°C
r4	0	Setpoint offset in energy saving	0°F/°C to 99°F/°C
r5	0	Cooling or heating operation	0 = Cooling 1 = Heating
r12	1	Position of the r0 differential	0 = Asymmetric 1 = Symmetric
COMPRESSOR			
PAR.	DEF.	COMPRESSOR	MIN. - MAX.
C0	0	Compressor on delay after power-on	0 min to 240 min
C2	3	Compressor off minimum time	0 min to 240 min
C3	0	Compressor on minimum time	0 s to 240 s
C4	0	Compressor off time during cabinet probe alarm	0 min to 240 min
C5	10	Compressor on time during cabinet probe alarm	0 min to 240 min
C6	176	Threshold for high condenser temperature warning	0°F/°C to 199°F/°C Differential = 4°F/2°C
C7	194	Threshold for high condenser temperature alarm	0°F/°C to 199°F/°C
C8	1	High condenser temperature alarm delay	0 min to 15 min
DEFROST (if r5 = 0)			
PAR.	DEF.	DEFROST (if r5 = 0)	MIN. - MAX.
d0	8	Automatic defrost interval	0 h to 99 h 0 = Only manual If d8 = 3, maximum interval
d2	46	Threshold for defrost end	-99°F/°C to 99°F/°C
d3	30	Defrost duration	0 min to 99 min If P4 = 1, maximum duration
d4	0	Enable defrost at power-on	0 = no 1 = yes
d5	0	Defrost delay after power-on	0 min to 99 min
d6	1	Value displayed during defrost	0 = Cabinet temperature 1 = Display locked 2 = dEF label
d7	2	Dripping time	0 min to 15 min
d8	0	Defrost interval counting mode	0 = Device on hours 1 = Compressor on hours 2 = Hours evaporator temperature < d9 3 = Adaptive
d9	32	Evaporation threshold for automatic defrost interval counting	-99°F/°C to 99°F/°C
d11	0	Enable defrost timeout alarm	0 = no 1 = yes
d18	40	Adaptive defrost interval	0 min to 999 min If compressor on and evaporator temperature < d22 0 = Only manual
d19	6	Threshold for adaptive defrost, relative to optimal evaporation temperature	0°F/°C to 40°F/°C Optimal evaporation temperature - d19
d20	180	Compressor on consecutive time for defrost	0 min to 999 min 0 = Disabled
d22	-4	Evaporation threshold for adaptive defrost interval counting, relative to optimal evaporation temperature	0°F/°C to 19°F/°C Optimal evaporation temperature + d22
ALARMS			
PAR.	DEF.	ALARMS	MIN. - MAX.
A1	-20	Threshold for low temperature alarm (relative to setpoint)	0°F/°C to 99°F/°C SP - A1 0 = Disabled
A4	20	Threshold for high temperature alarm (relative to setpoint)	0°F/°C to 99°F/°C SP + A4 0 = Disabled
A6	12	High temperature alarm delay after power-on	0 min to 99 min x 10
A7	15	High and low temperature alarms delay	0 min to 240 min
A11	4	High and low temperature alarms reset differential	1°F/°C to 15°F/°C
DIGITAL INPUTS			
PAR.	DEF.	DIGITAL INPUTS	MIN. - MAX.
i0	1	Door switch or multi-purpose input function	0 = None 1 = Compressor off 2 = Energy saving 3 = iA alarm 4 = iA alarm + compressor off
i1	0	Door switch or multi-purpose input activation	0 = With contact closed 1 = With contact open
i2	30	Open door alarm delay	-1 min to 120 min If i0 = 3, multi-purpose input alarm delay If i0 = 4, compressor on delay after alarm reset -1 = Disabled
i3	15	Regulation inhibition maximum time with door open	-1 min to 120 min -1 = Until the closing
i10	0	Door closed consecutive time for energy saving	0 min to 999 min After regulation temperature < SP 0 = Disabled
i13	180	Number of door openings for defrost	0 to 240 0 = Disabled
i14	32	Door open consecutive time for defrost	0 min to 240 min 0 = Disabled
ENERGY SAVING (if r5 = 0)			
PAR.	DEF.	ENERGY SAVING (if r5 = 0)	MIN. - MAX.
HE2	0	Energy saving maximum duration	0 min to 999 min 0 = Until the door opening
HE3	2	No operation on the keyboard consecutive time for low consumption	0 min to 240 min 0 = Disabled
SAFETIES			
PAR.	DEF.	SAFETIES	MIN. - MAX.
POF	1	Enable ON/STAND-BY key	0 = No 1 = Yes
PAS	0	Password	-99 to 999 0 = Disabled

8 ALARMS

COD.	DESCRIPTION	RESET	REMEDIES
Pr1	Cabinet probe alarm	Automatic	- Check P0
Pr2	Auxiliary probe alarm	Automatic	- Check probe integrity - Check electrical connection
AL	Low temperature alarm	Automatic	Check A1
AH	High temperature alarm	Automatic	Check A4
id	Open door alarm	Automatic	Check i0 and i1
COH	High condenser temperature warning	Automatic	Check C6
CSd	High condenser temperature alarm	Manual	- Switch the device off and on - check C7
IA	Multi-purpose input alarm	Automatic	Check i0 and i1
dFd	Defrost timeout alarm	Manual	- Tap any key - Check d2, d3, and d11

9 ELECTRICAL RATINGS

Output	Units	cULus (UL 60730)		CE (EN 60730)
	Applied voltage at 60 Hz	120 VAC	240 VAC	240 VAC
K1 compressor relay	Resistive amperes	10	10	10
	Inductive amperes	—	—	2
	Full load amperes	10	10	—
	Locked rotor amperes	60	60	—

10 TECHNICAL SPECIFICATIONS

Purpose of the control device	Function controller
Construction of the control device	Built-in electronic device
Container	Black, self-extinguishing
Category of heat and fire resistance	D
Measurements	2 15/16 in. x 1 5/16 in. x 1 9/16 in. (75 mm x 33 mm x 39.5 mm)
Mounting methods for the control device	Fit the controller to a panel with the snap-in brackets supplied
Degree of protection provided by the covering	IP65 in front
Connection method	Fixed screw terminal blocks for wires up to 2.5 mm ²
Maximum permitted length for connection cables	
Power supply: 32.8 ft (10 m)	Analog inputs: 32.8 ft (10 m)
Digital inputs: 32.8 ft (10 m)	Digital outputs: 32.8 ft (10 m)
Operating temperature	From 32°F to 131°F (from 0°C to 55°C)
Storage temperature	From -13°F to 158°F (from -25°C to 70°C)
Operating humidity	Relative humidity without condensate from 10% to 90%
Pollution status of the control device	2
Compliance	
Europe	JCI declares product compliance meets requirements of EMC, LVD, and RoHS Directives.
USA	UL Recognized Component, SDFY2.SA516; FCC Part 15 Subpart B Class A
Canada	UL Recognized Component, SDFY8.SA516; ICES-003 Class A
Power supply	TC3X21N5x 115 VAC (+10% -15%), 50/60 Hz (+/- 3Hz), max. 2 VA TC3X21N7x 230 VAC (+10% -15%), 50/60 Hz (+/- 3Hz), max. 2 VA
Grounding methods for the control device	None
Rated impulse-withstand voltage	4 KV
Over-voltage category	III
Software class and structure	A
Analog inputs	1 for NTC probes (cabinet probe)
NTC probes	Sensor type B3435 (10 KΩ at 77°F, 25°C) Measurement field -40°F to 221°F (-40°C to 105°C) Resolution 1°F (0.1°C)
Other inputs	Input configurable for analog input (auxiliary probe) or digital input (door switch or multi-purpose, dry contact)
Dry contact	Contact type 5 VDC, 1.5 mA Power supply None Protection None
Digital outputs	1 electro-mechanical relay (compressor relay)
Type 1 or Type 2 actions	Type 1
Additional features of Type 1 or Type 2 actions	C
Displays	3 digits custom display with function icons

11 PRODUCT WARRANTY

This product is covered by a limited warranty, details of which can be found at www.johnsoncontrols.com/buildingwarranty

12 SOFTWARE TERMS

Use of the software that is in (or constitutes) this product, or access to the cloud, or hosted services applicable to this product, if any, is subject to applicable end-user license, open-source software information, and other terms set forth at www.johnsoncontrols.com/techterms. Your use of this product constitutes an agreement to such terms.

13 SINGLE POINT OF CONTACT

APAC	Europe	NA/SA
JOHNSON CONTROLS C/O CONTROLS PRODUCT MANAGEMENT NO. 32 CHANGJIJANG RD NEW DISTRICT WUXI JIANGSU PROVINCE 214028 CHINA	JOHNSON CONTROLS WESTENDHOF 3 45143 ESSEN GERMANY	JOHNSON CONTROLS 507 E MICHIGAN ST MILWAUKEE WI 53202 USA

14 CONTACT INFORMATION

Contact your local branch office:
www.johnsoncontrols.com/locations
Contact Johnson Controls:
www.johnsoncontrols.com/contact-us

 **Important**
The device must be disposed of according to local regulations governing the collection of electrical and electronic waste.

This document and the solutions contained therein are the intellectual property of Penn and thus protected by the Italian Intellectual Property Rights Code (CPI). Penn imposes an absolute ban on the full or partial reproduction and disclosure of the content other than with the express approval of Penn. The customer (manufacturer, installer or end-user) assumes all responsibility for the configuration of the device. Penn accepts no liability for any possible errors in this document and reserves the right to make any changes, at any time without prejudice to the essential functional and safety features of the equipment.



Johnson Controls
507 E. Michigan St.
Milwaukee, WI 53202-5211
USA
www.penncontrols.com