

Electromotoric actuator

SSB161.05U



For Powermite MZ Series 2-way and 3-way globe valves

- Operating voltage AC/DC 24 V, positioning signal DC 0...10 V
- Self-calibrating to the valve stroke
- Direct mounting with coupling nut, no tools required
- Manual override
- Position and actuator motion indication (LED)
- Positioning force 45 lbf (200 N)
- Parallel operation of multiple actuators possible

Use

- For 2-way and 3-way Powermite 599 MZ Series globe valves, 599-01100 - 599-01139
- Typically in chilled ceiling, VAV, unit ventilators, fan coil unit and other terminal unit applications
- Max.10 units of SSB161.05U can operate in parallel, provided the controller output suffices.

Technical design

When the actuator is driven by DC 0...10 V positioning signal, it produces a stroke, which is transmitted to the valve stem.

DC 0...10 V control signal

- The valve opens / closes in proportion to the control signal at Y.
- At DC 0 V, the actuator stem is retracted, the normally closed valve is fully closed and the normally open valve is fully open.
- When no power is supplied, the actuator maintains its current position.

Y = Control signal Y [V]

H = Percentage of calibrated valve stroke

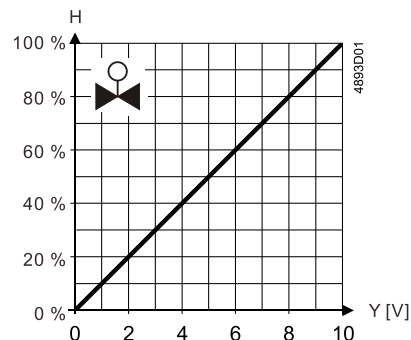

LED indication

Status	LED indication patterns
Variants	SSB161.05U 
Modulation: Stem retracting	Flashing green in sequence: LED1-->LED2-->LED3 (500 ms each)
Modulation: Stem extending	Flashing green in sequence: LED3-->LED2-->LED1 (500 ms each)
Stem position	At H0 - H40: Constant green (LED3) At H40 - H60: Constant green (LED2) At H60 - H100: Constant green (LED1)
Calibration	Flashing green (LED2): 100 ms on, 100 ms off
Error	Constant red (LED2)
Manual operation	Flashing green/red alternatively (LED2): Green 500 ms, red 500 ms

Type summary

Type	Stock number	Operating voltage	Running speed	Running time 5.5 mm	Control signal	Actuator characteristic
SSB161.05U	S55180-A151	AC/DC 24 V	5 s/mm	27.5 s ± 25 %	DC 0...10 V	Linear

Accessories

Product Type	Stock Number	Picture	Name	Conduit interface
ASY101	S55845-Z277		Conduit Adaptor	3/8 inch flex conduit

Ordering

When ordering, specify both type and quantity.

Example:

Type	Stock number	Designation	Quantity
SSB161.05U	S55180-A151	Electromotoric actuator	2

Delivery

Valves and actuators can be ordered assembled in the factory or ordered separately. For easier valve assembly, actuators ordered separately have the actuator stem fully retracted.

Equipment combinations

Valves

Combinable valves for SSB161.05U- 2-way Powermite 599 MZ Series

Action	Nominal Line Size		Flow Rate		Connection
	Inch	mm	Cv	Kvs	FxF
Normally Closed	0.5	15	0.4	(0.34)	599-01100
	0.5	15	0.63	(0.54)	599-01102
	0.5	15	1.0	(0.85)	599-01104
	0.5	15	1.6	(1.37)	599-01106
	0.5	15	2.5	(2.15)	599-01108
	0.5	15	4	(3.44)	599-01110
	0.75	20	6.3	(5.43)	599-01112
	1	25	10	(8.6)	599-01114
Normally Open	0.5	15	0.4	(0.34)	599-01115
	0.5	15	0.63	(0.54)	599-01117
	0.5	15	1.0	(0.85)	599-01119
	0.5	15	2.5	(2.15)	599-01123
	0.5	15	4	(3.44)	599-01126
	0.75	20	6.3	(5.43)	599-01129
	1	25	10	(8.6)	599-01131

Combinable valves for SSB161.05U – 3-way Powermite 599 MZ Series

Nominal Line Size		Flow Rate		Connection
Inch	mm	Cv	Kvs	FxF
0.5	15	0.4	(0.34)	599-01132
0.5	15	0.63	(0.54)	599-01133
0.5	15	1.0	(0.85)	599-01134
0.5	15	1.6	(1.37)	599-01135
0.5	15	2.5	(2.15)	599-01136
0.5	15	4	(3.44)	599-01137
0.75	20	6.3	(5.43)	599-01138
1.00	25	10	(8.6)	599-01139

Product documentation

Topic	Title	Document ID
Installation	Mounting instruction	A6V13122037
Standards and directives	CE declarations	A5W00254962A
	RCM conformity	A5W00254983A
Environmental compatibility	Environmental declarations	A5W00242127A

Related documents such as the environmental declarations, CE declarations, etc., can be downloaded from the following Internet address:

www.siemens.com/bt/download

Notes

Engineering

The actuators must be electrically connected in accordance with local regulations (see "Connection diagrams").

⚠ CAUTION	
	<p>National safety regulations</p> <p>Failure to comply with national safety regulations may result in personal injury and property damage.</p> <ul style="list-style-type: none"> Observe national provisions and comply with the appropriate safety regulations.

Observe permissible temperatures (see "Technical data [► 9]").

Mounting

⚠ WARNING	
	<ul style="list-style-type: none">• Do not use pipe wrenches, pliers or similar tools.• Avoid lateral pressure or (cable) tension on the mounted actuator!

Valve and actuator are easy to assemble on site before commissioning:

- Remove protective cover from the valve body.
- Position the actuator and tighten the union nut manually.
- See "Mounting instructions" for graphical instructions.

Orientation

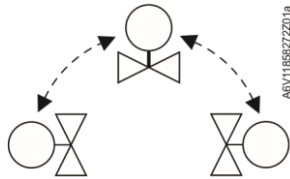

Commissioning

When commissioning, check both wiring and functioning of the actuator.

- Actuator stem extends Normally open valve closes, normally closed valve opens
- Actuator stem retracts Normally open valve opens, normally closed valve closes

NOTICE	
	The actuator must be commissioned only with a correctly mounted valve in place!

Self-calibration

When operating voltage is applied, the actuator self-calibrates (fully retracted → fully extended → setpoint).

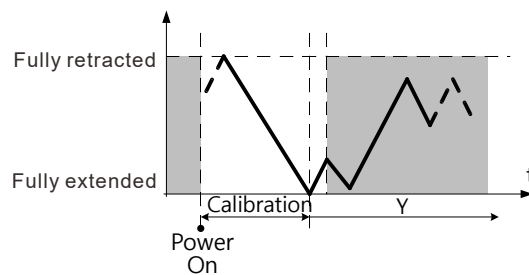

⚠ CAUTION	
	Never intervene manually during self-calibration.

NOTICE



- Correct calibration is only possible with valve stroke > 0.05 inch (1.2 mm). Valve stroke < 1.2 mm results in calibration failure.
- If calibration fails, the actuator performs another calibration automatically after 10 seconds.
- After three failed calibration attempts, the actuator stem remains in the extended position and the valves are open.

Manual operation

A 3-mm hexagonal wrench can be used to move the actuator to any position.

To move the actuator stem manually

1. Open the cover using a proper screwdriver.
2. Press and hold down button (a) illustrated below for at least three seconds.
 - The actuator ignores any control signal from the controller.
3. Adjust the position of the actuator stem by rotating hexagonal wrench (b) illustrated below clockwise or counter-clockwise.
 - The actuator stem moves down if you rotate clockwise; it moves up if you rotate counter-clockwise. The manually set position is retained.
4. To exit manual operation mode, press and hold down button (a) illustrated below again for at least three seconds.
 - The actuator runs a self-calibration automatically. Control signal sent from the controller takes effect.
5. Close the cover.

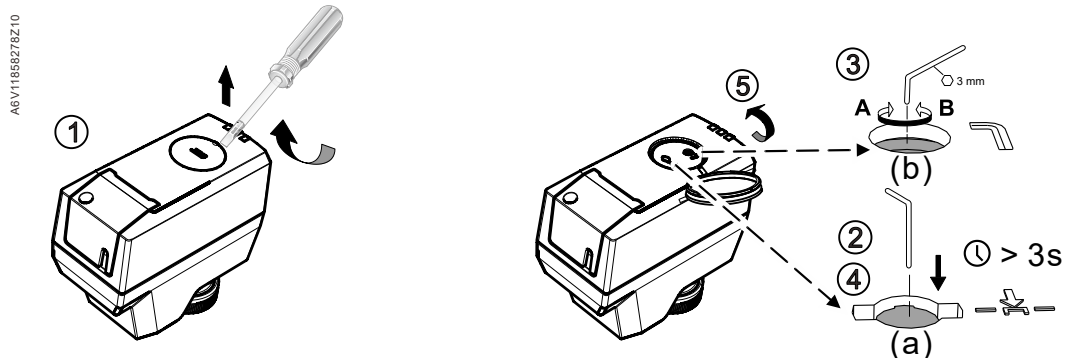

NOTICE



If operating voltage is applied to actuator, press button (a) before and after manually adjusting the position of the actuator stem. If no operating voltage and control signal are applied, manual operation can be done without pressing button (a).

Cabling operation

1. Unscrew cover screw
2. Remove cover
3. Connect or disconnect wire terminals (terminal block is removable)
4. Install the cover
5. Screw in the cover screw

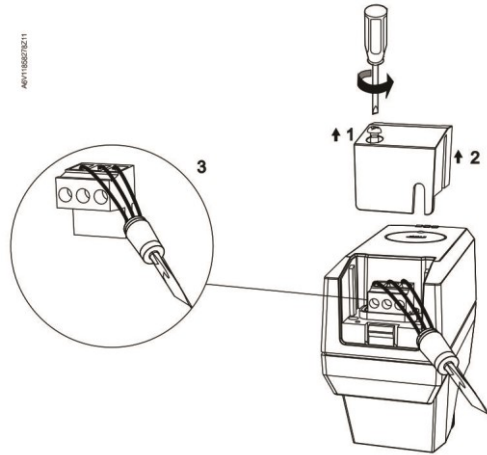

Maintenance

The actuators require no maintenance.

⚠ WARNING	
	Operating voltage must be switched off during any maintenance!

NOTICE	
!	<p>When carrying out service work on the plant, note the following:</p> <ul style="list-style-type: none"> • Switch off operating voltage. • If necessary, disconnect electrical connections from the terminals. • The actuator must be commissioned only with a correctly mounted valve in place!

Repair

The actuators cannot be repaired; the complete unit must be replaced.

Disposal

	<p>The device is considered an electronic device for disposal and may not be disposed of as domestic waste.</p> <ul style="list-style-type: none"> • Dispose of the device through channels provided for this purpose. • Comply with all local and currently applicable laws and regulations.
--	---

Warranty

Technical data on specific applications are valid only together with Siemens products listed under "Equipment combinations". Siemens rejects any and all warranties in the event that third-party products are used.

Software license overview

These devices use Open Source Software (OSS). All Open Source Software components used in the product (to include copyrights and licensing agreement) are available at <http://siemens.com/bt/download>.

Firmware version	OSS document		Device
	Document ID	Title	
2.10.0 or above	A6V13503690	Readme OSS for Modulating Room Actuator 200N, 300N	All

Technical data

Power supply	
Operating voltage	AC 24 V (± 15 %) or DC 24 V (± 20 %)
Frequency	50/60 Hz
Power consumption	3 VA (AC); 1.2 W (DC)
Primary fuse or breaker rating	External, 2 A quick blow

Signal input	
Control signal	DC 0...10 V
Input impedance	100 kOhm
Parallel operation (number of actuators)	Max. 10 ¹⁾

1) Provided that the controller output is sufficient.

Operating data	
Position with de-energized contact Y	See "Technical design [► 2]"
Running speed (time for 5.5 mm)	< 5 s/mm ± 25 % (27.5 s ± 25 %)
Positioning force	45 lbf (200 N)
Stroke	0.05 to 0.25 inch (1.2...6.5 mm)
Permissible temperature of medium in the connected valve	34 to 248 °F (1...120 °C)

Electrical connection	
Permissible length for signal lines	65 ft (20 m)
Wire cross section	18...20 AWG (0.5...0.75 mm ²)
Cable diameter	<0.2 inch (5 mm)

Mounting	
Connection to valve	Coupling nut with internal thread
Orientation	Above horizontal

Standards	
EU conformity declaration (CE)	A5W00254962A
RCM conformity declaration	A5W00254983A
UK conformity declaration (UKCA)	A5W00257055A
Housing protection degree	NEMA 2 / IP20 (EN 60529)
Protection class according to EN 60730	III
Pollution degree	2

Standards	
Overvoltage category	I
Environmental compatibility	The product environmental declaration (A5W00242127A) contains data on environmentally compatible product design and assessments (RoHS compliance, materials composition, packaging, environmental benefit, disposal).
UL Approval	UL as per UL60730-1, UL60730-2-14 http://ul.com/database
Federal Communications Commission	cUL as per CSA – CAN E60730-1, E730-2-14 FCC CFR 47 Part 15 Class B
ICES003	CAN ICES-3 (B)/NMB-3(B)

FCC regulations

Modification of this device to receive cellular radio telephone service signals is prohibited under FCC rules and federal law.

This equipment has been tested and found to comply with the limits for a Class B digital device, pursuant to part 15 of the FCC Rules. These limits are designed to provide reasonable protection against harmful interference in a residential installation. This equipment generates, uses and can radiate radio frequency energy and, if not installed and used in accordance with the instructions, may cause harmful interference to radio communications. However, there is no guarantee that interference will not occur in a particular installation. If this equipment does cause harmful interference to radio or television reception, which can be determined by turning the equipment off and on, the user is encouraged to try to correct the interference by one or more of the following measures:

Reorient or relocate the receiving antenna.

Increase the separation between the equipment and receiver.

Connect the equipment into an outlet on a circuit different from that to which the receiver is connected.

Consult the dealer or an experienced radio/TV technician for help.

Changes or modifications not expressly approved by the party responsible for compliance could void the user's authority to operate the equipment.

Statement

This device complies with part 15 of the FCC Rules. Operation is subject to the following two conditions: (1) This device may not cause harmful interference, and (2) this device must accept any interference received, including interference that may cause undesired operation.

Housing color	
Cover/base	2003, Ti-Gray
Coupling nut	RAL 9017

General ambient conditions			
	Operation	Transport	Storage
Temperature	34 to 122°F (1...50 °C)	-13 to 158°F (-25...70 °C)	-13 to 158°F (-25...70 °C)
Humidity	5...95 % r.h. non condensing	<95 % r.h. non condensing	5...95 % r.h. non condensing
Atmospheric pressure	Min. 700 hPa, corresponding to max. 3,000 m above sea level	-	-

Material	
Cover/base	PC + ABS

Weight
7.8 ounces (220 g)

Diagrams

Connection terminals



- G0 System neutral
- Y Control signal DC 0...10 V
- G System potential (AC/DC 24 V)

Connection diagrams

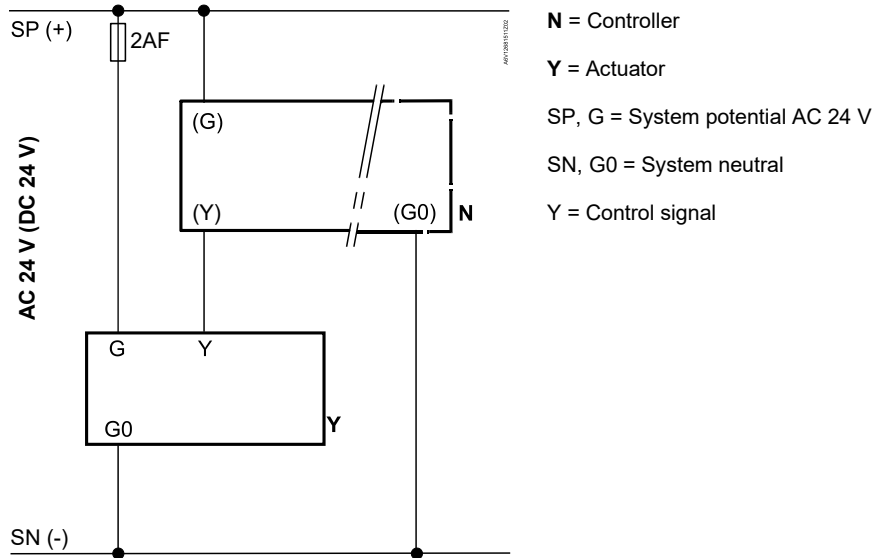

Dimensions

mm (inch)

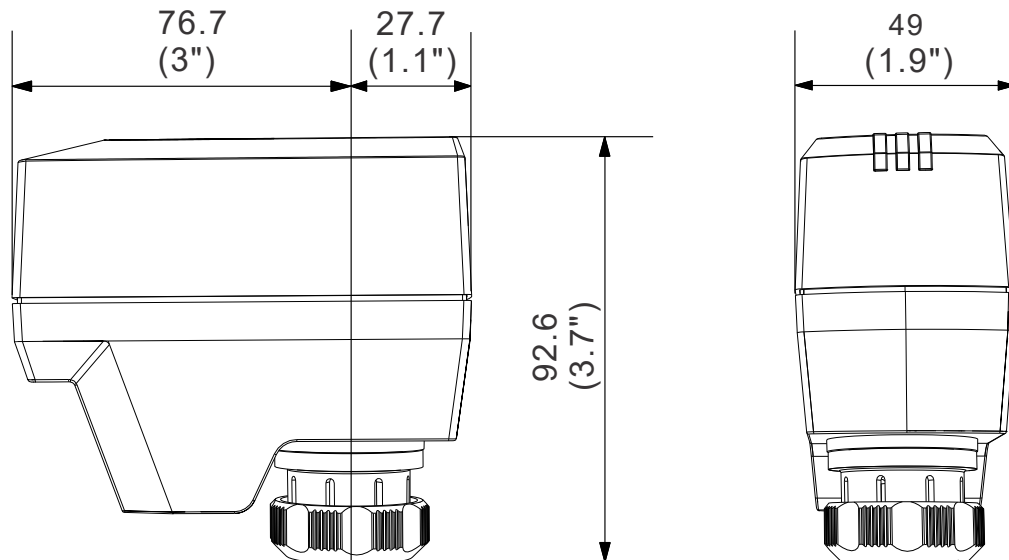

Revision numbers

Type	Valid from rev. no.
SSB161.05U	..A

Issued by
Siemens Switzerland Ltd
Smart Infrastructure
Global Headquarters
Theilerstrasse 1a
CH-6300 Zug
+41 58 724 2424
www.siemens.com/buildingtechnologies

© Siemens Switzerland Ltd, 2023
Technical specifications and availability subject to change without notice.

Document ID A6V12681516_enUS_a
Edition 02/09/2023